

# Installation Instructions

Document Number: 466-1758-ITI Rev. B  
April 2001

## Advent™ Commercial Burglary and Home Navigator System

Commercial Burglary Panels	250 Zone—60-562-01 132 Zone—60-562-04
Home Navigator Panels	250 Zone—60-562-05 132 Zone—60-562-02

## Contents

About This Manual .....	1	I/O Settings .....	34
Special Installation Requirements .....	1	Accessory Modules .....	34
UL Listed Installations .....	1	Programmable Output Settings .....	36
California State Fire Marshall Listed Installations .....	4	Alarm Settings .....	38
Planning the Installation .....	4	System Settings .....	39
Panel Types .....	4	Miscellaneous Settings .....	42
Panel Components .....	4	Remote Downloader Programming .....	44
Panel Terminals .....	4	Advent Downloader Programming .....	44
BUS Device Headers .....	5	Installing Line Carrier Devices .....	44
Panel Devices .....	5	Programming the Panel House Code .....	44
SuperBus 2000 Touchpads .....	5	Installing X-10 Modules .....	44
SuperBus 2000 Modules .....	5	Adding Lights/Devices to Program Memory .....	44
SnapCards .....	5	Testing the System .....	45
Installing the System .....	5	Basic System Commands .....	45
Determining the Panel Location .....	6	Testing Panel Backup Battery(s) .....	45
Running Wires to the Panel Location .....	6	Testing Hardwire and Wireless Zones/Sensors .....	45
System Wire Lengths .....	6	If a Wireless Sensor Fails the Zone/Sensor Test .....	46
Mounting the Panel .....	7	Testing Outputs and Sirens .....	46
Installing Optional Panel SnapCards .....	7	Testing Lights and Devices .....	46
Connecting SuperBus 2000 Modules and Touchpads .....	7	Testing Phone Communication .....	47
SuperBus 2000 Touchpads .....	8	Testing Central Station Communication .....	47
SuperBus 2000 Modules .....	8	Adjusting Touchpad Display Contrast .....	47
Voice Siren 25/70 Volt Converter Card (60-773) .....	10	Troubleshooting .....	48
Connecting Detection Devices to Panel Zone Inputs .....	10	Appendix A: System Configuration Worksheets .....	56
Connecting Intrusion Detection Devices .....	10	Determining Maximum Panel Wire Length .....	57
Connecting Speakers .....	11	Other System Devices .....	57
Connecting Listed Sirens .....	12	X-10 Modules and Device Settings .....	58
Installing an RJ-31X Phone Jack (13-081) .....	12	Partition/Area Descriptions .....	59
Connecting the Phone Line to the Panel with a DB-8 Cord (49-442) .....	13	SuperBus 2000 Device Information .....	60
Mounting/Connecting an AC Power Transformer .....	13	Zone and Sensor Information .....	61
Installing Panel Backup Battery(s) .....	14	Menu Lights and Outputs .....	67
Powering Up the Panel .....	14	Programmable Output Type Information .....	68
Programming the Panel .....	14	Access Codes and Authority Level Settings .....	69
Using the Downloader Software to Program the Panel .....	15	Item Numbers Index and Record .....	70
Using an Alphanumeric Touchpad to Program the Panel .....	15	Appendix B: Reference Tables .....	79
Entering/Exiting Program Mode .....	15	Contact ID Codes and Event Types .....	96
Using Item Numbers .....	15	Additional CID Reporting .....	99
Codes .....	23	Smoke and Heat Detector Installation .....	101
Specific Phone Number Settings .....	25		
Phone Access Settings .....	29		
Zone Settings .....	31		

# Notices

## FCC Part 15 Information to the User

Changes or modifications not expressly approved by Interactive Technologies, Inc. can void the user's authority to operate the equipment.

### FCC Part 15 Class A (Commercial)

This equipment has been tested and found to comply with the limits for a class A digital device, pursuant to part 15 of the FCC rules. These limits are designed to provide reasonable protection against harmful interference when the equipment is operated in a commercial environment.

This equipment generates, uses, and can radiate radio frequency energy and, if not installed and used in accordance with the instruction manual, may cause harmful interference to radio communications. Operation of this equipment in a residential area is likely to cause harmful interference in which case users will be required to correct the interference at their own expense.

### FCC Part 15 Class B (Residential)

This equipment has been tested and found to comply with the limits for a Class B digital device, pursuant to part 15 of the FCC Rules. These limits are designed to provide reasonable protection against interference in a residential installation.

This equipment generates, uses, and can radiate radio frequency energy and, if not installed and used in accordance with the instructions, may cause harmful interference to radio communications. However, there is no guarantee that interference will not occur in a particular installation.

If this equipment does cause harmful interference to radio or television reception, which can be determined by turning the equipment off and on, the user is encouraged to try to correct the interference by one or more of the following measures:

- Install a quality radio or television outdoor antenna if the indoor antenna is not adequate.
- Reorient or relocate the panel.
- Move the panel away from the affected equipment.
- Move the panel away from any wire runs to the affected equipment.
- Connect the affected equipment and the panel to separate outlets, on different branch circuits.
- Consult the dealer or an experienced radio/TV technician for help.
- Send for the FCC booklet *How to Identify and Resolve Radio-TV Interference Problems*, available from the U.S. Government Printing Office, Washington, D.C. 20402. Stock Number: 004-000-00345-4.

## FCC Part 68

This equipment complies with Part 68 of the FCC Rules. Located on this equipment is a label that contains, among other information, the FCC registration number and the ringer equivalence number (REN) for this equipment. If requested, this information must be provided to the telephone company.

The REN is used to determine the maximum number of devices that may be connected to your telephone line. In most areas, the sum of all device RENs should not exceed five (5.0).

If this equipment causes harm to the telephone network, the telephone company may temporarily disconnect your service. If possible, you will be notified in advance. When advance notice is not practical, you will be notified as soon as possible. You will also be advised of your right to file a complaint with the FCC.

Your telephone company may make changes in its facilities, equipment, operations, or procedures that could affect the proper operation of your equipment. You will be given advanced notice in order to maintain uninterrupted service.

This equipment may not be used on coin service provided by the telephone company. Connection to party lines is subject to state tariffs.

## Declaration of Conformity (DoC)

Interactive Technologies, Inc. declares that the ITI model no. 60-792-95R is in conformity with Part 15 of the FCC Rules. Operation of this product is subject to the following two conditions: (1) This device may not cause harmful interference, and (2) this device must accept any interference received, including interference that may cause undesired operation.

## Canada Notice

The Canadian Department of Communications label identifies certified equipment. This certification means that the equipment meets certain telecommunications network protective, operational, and safety requirements. The department does not guarantee the equipment will operate to the user's satisfaction.

Before installing this equipment, users should ensure that it is permissible to be connected to the facilities of the local telecommunications company. The equipment must also be installed using an acceptable method of connection. In some cases, the company's inside wiring associated with a single-line individual service may be extended by means of a certified connector assembly (telephone extension cord). The customer should be aware that compliance with the above conditions may not prevent degradation of service in some situations.

Repairs to certified equipment should be made by an authorized Canadian maintenance facility designated by the supplier. Any repairs or alterations made by the user to this equipment, or equipment malfunctions, may give the telecommunications company cause to request the user to disconnect the equipment.

For your protection, make sure that the electrical ground connections of the power utility, telephone lines, and internal metallic water pipe system, if present, are connected together.

## Caution

**Do not attempt to make connections yourself. Contact the appropriate electrician or electric inspections authority.**

The Load Number (LN) assigned to each terminal device denotes the percentage of the total load to be connected to a telephone loop that is used by the device to prevent overloading. The termination on a loop may consist of any combination of devices subject only to the requirement that the total of the LNs of all the devices does not exceed 100. Load Number: 0.2B AC

"AVIS: - L'étiquette du ministère des Communications du Canada identifie le matériel homologué. Cette étiquette certifie que le matériel est conforme à certaines normes de protection, d'exploitation et de sécurité des réseaux de télécommunications. Le ministère n'assure toutefois pas que le matériel fonctionnera à la satisfaction de l'utilisateur.

Avant d'installer ce matériel, l'utilisateur doit s'assurer qu'il est permis de le raccorder aux installations de l'entreprise locale de télécommunication. Le matériel doit également être installé en suivant une méthode acceptée de raccordement. Dans certains cas, les fils intérieurs de l'entreprise utilisés pour un service individuel à ligne unique peuvent être prolongés au moyen d'un dispositif homologué de raccordement (cordon prolongateur téléphonique interne). L'abonné ne doit pas oublier qu'il est possible que la conformité aux conditions énoncées ci-dessus n'empêche pas la dégradation du service dans certaines situations. Actuellement, les entreprises de télécommunication ne permettent pas que l'on raccorde leur matériel à des jacks d'abonné, sauf dans les cas précis prévus par les tarifs particuliers de ces entreprises.

Les réparations de matériel homologué doivent être effectuées par un centre d'entretien canadien autorisé désigné par le fournisseur. La compagnie de télécommunications peut demander à l'utilisateur de débrancher un appareil à la suite de réparations ou de modifications effectuées par l'utilisateur ou à cause de mauvais fonctionnement.

Pour sa propre protection, l'utilisateur doit s'assurer que tous les fils de mise à la terre de la source d'énergie électrique, des lignes téléphoniques et des canalisations d'eau métalliques, s'il y en a, sont raccordés ensemble. Cette précaution est particulièrement importante dans les régions rurales.

**Avertissement. - L'utilisateur ne doit pas tenter de faire ces raccordements lui-même; il doit avoir recours à un service d'inspection des installations électriques, ou à un électricien, selon le cas".**

Une note explicative sur les indices de charge (voir 1.6) et leur emploi, à l'intention des utilisateurs du matériel terminal, doit être incluse dans l'information qui accompagne le matériel homologué. La note pourrait être rédigée selon le modèle suivant:

"L'indice de charge (IC) assigné à chaque dispositif terminal indique, pour éviter toute surcharge, le pourcentage de la charge totale qui peut être raccordée à un circuit téléphonique bouclé utilisé par ce dispositif. La terminaison du circuit bouclé peut être constituée de n'importe quelle somme des indices de charge de l'ensemble des dispositifs ne dépassant pas 100."

L'indice de charge de cet produit est \_\_\_\_\_.

## About This Manual

This manual provides information for planning, installing, programming, and testing an Advent Commercial security or Home Navigator system. When necessary, this manual refers you to other documentation included with compatible peripherals.

“Appendix A: System Configuration Worksheets” on page 58 are included for you to record hardware layout and software programming settings.

### About the User Guide

The *User Guide* contains user worksheets that should be filled out during the installation and programming of the system.

## Special Installation Requirements

### Commercial Burglary Panel

The commercial burglary panel can be used as an intrusion alarm system. Follow the installation guidelines below:

- Some installations may require configurations dictated by city/state codes, insurance, or Underwriter’s Laboratories (UL). See the following section “UL Listed Installations” for various UL component and configuration listings.

### UL Listed Installations

This section describes the minimum requirements for different UL Listed installations.

#### Basic System

- Commercial Burglary (60-562-01, 60-562-04) or Home Navigator (60-562-02, 60-562-05) Control Panel
- SuperBus 2000 VFD (60-804-01) or LCD (60-803-01) Alphanumeric Touchpad
- 24 VAC output, 100 VA Class I, 110VAC, 60 Hz (60-830) or 24 VAC output, 100 VA Class II, 110VAC, 60 Hz (60-823) Line Carrier AC Power Transformer
- 17.2 AH or 18.0 AH Backup Battery(s) (60-781)
- Backup Battery Cable Assemblies (49-484 [red] and 49-476 [black])
- UL listed 4 ohm, 15W Speaker
- 2K ohm EOL Resistor(s) (49-467)

#### Police Station Connected Burglary Alarm Units and Systems (UL 365)

Basic system using Commercial Burg control panel (60-562-01 or 60-562-04).

The basic system may also include:

- Hardwire Magnetic Contact (13-068 or 13-071) or Wireless Learn Mode Door/Window Sensor (60-362).
- A SuperBus 2000 Commercial RF Transceiver (60-821) for use with listed wireless signaling devices.
- A SuperBus 2000 Printer or Automation Module (60-783) for use with a listed printer.
- A SuperBus 2000 Dual Phone Line Module (60-768) for

expansion to primary and secondary phone line reporting.

### System Setup and Programming

The system Feature Numbers shall be set as follows in UL 365 listed systems:

**Table 1: UL 365 Listed System Settings**

Feature No.	Feature	Required Setting
xx002	Siren Sound Time	16 min. minimum
xx003	Entry Delay	45 sec. maximum
xx004	Exit Delay	60 sec. maximum
yy003	Number of Attempts	5 min. 10 maximum
yy004	Communication Format	0 Contact ID
xx088	Report Partition/Area Events	1-On
xx092	Auto Forced Arming	0-Off
xx097	Exterior Siren Arming Verification	0-Off
xx098	Local Closing Report Verification	1-On
xx102	Exit Delay Reset	0-Off
xx108	Local Trouble Annunciation at LTIME	1-On
17034	Auto Phone Test Frequency	1 Day
17036	AC Stable Time	90 sec. maximum
17041	AC Report Delay	6-12 hours
17049	Supervisory Time A	4 hours
17069	Phone Trouble Disable	0-Off
17072	RF Jam Detect Sound Enable	1-On
17073	Automatic Panel Backup Battery Test Interval	1=4 hours
17076	Commercial/Residential	1-Commercial
17078	Detect RF Receiver Failure	1-On
17079	Alarm Messages Played at High Volume	1-On (High)
17096	Report System Events	1-On
47004	#2 Supervisory Time Zone Attribute (all zones) #4 Hardwire Smoke Verify Zone Attribute	Set to 4 hours 0-Off

xx = Two digit partition number.  
yy = Two digit non-pager phone number.

#### Local Burglar Alarm Units and Systems (UL 609)

Basic system using Commercial Burg control panel (60-562-01 or 60-562-04), plus:

- Hardwire Magnetic Contact (13-068 or 13-071) or Wireless Learn Mode Door/Window Sensor (60-362).

The basic system may also include:

- A SuperBus 2000 Commercial RF Transceiver (60-821) for use with listed wireless signaling devices.
- A SuperBus 2000 Printer or Automation Module (60-783) for use with a listed printer.

- A SuperBus 2000 Dual Phone Line Module (60-768) for expansion to primary and secondary phone line reporting.

**System Setup and Programming**

The system Feature Numbers shall be set as follows in UL 609 listed systems:

**Table 2: UL 609 Listed System Settings**

Feature No.	Feature	Required Setting
xx002	Siren Sound Time	16 min. minimum
yy004	Communication Format	0 Contact ID
xx088	Report Partition/Area Events	1-On
xx092	Auto Forced Arming	0-Off
xx097	Exterior Siren Arming Verification	0-Off
xx102	Exit Delay Reset	0-Off
17034	Auto Phone Test Frequency	1 Day
17036	AC Stable Time	90 sec. maximum
17041	AC Report Delay	6-12 hours
17049	RF Supervisory Time	4 hours
17069	No Phone Line	0-Off
17072	Enable RF Jam Detect	1-On
17073	Automatic Panel Backup Battery Test Interval	1=4 hours
17076	Commercial/Residential	1-Commercial
17078	Detect RF Receiver Failure	1-On
17079	Alarm Messages Played at High Volume	1-On (High)
17096	Report System Events	1-On
47004	#2-Supervisory Time Zone Attribute (all zones) #4-Hardwire Smoke Verify Zone Attribute	Set to 4 hrs 0-Off

xx = Two digit partition number.  
yy = Two digit non-pager phone number.

**Household Fire Warning System Units (UL 985)**

Basic system, plus:

- Hardwire Smoke Detector (Compatibility Identifier 60-562, 20 per loop maximum):
  - System Sensor models 2100S, 2100TS, 2100D, 2100TD, 2400, or 2400TH added (learned) into Zone Type 80.
  - Sentrol models 429AT, 521B, or 521BXT added (learned) into Zone Type 80.

The basic system may also include:

- SuperBus 2000 Commercial RF Transceiver (60-821) for use with listed wireless signaling devices.
- Wireless Smoke Sensor (60-506-319.5 or 60-848-95) added (learned into Zone Type 80).
- SuperBus 2000 Printer or Automation Module (60-783) for use with a listed printer.

- SuperBus 2000 Dual Phone Line Module (60-768) for expansion to primary and secondary phone line reporting.

**System Setup and Programming**

The system Feature Numbers shall be set as follows in UL 985 listed systems:

**Table 3: UL 985 Listed System Settings**

Feature No.	Feature	Required Setting
xx002	Siren Sound Time	4 min. minimum
xx003	Entry Delay	45 sec. maximum
xx004	Exit Delay	60 sec. maximum
yy004	Communication Format	0 Contact ID
xx085	Enable Police Panic Keys	1-On
xx086	Enable Auxiliary Medical Panic Keys	1-On
xx087	Enable Fire Panic Keys	1-On
xx088	Report Partition/Area Events	1-On
xx092	Auto Forced Arming	0-Off
xx097	Exterior Siren Arming Verification required	0-Off
xx102	Exit Delay Reset	0-Off
xx108	Local Trouble Annunciation at LTIME.	1-On
17036	AC Stable Time	90 sec. maximum
17041	AC Report Delay	6-12 hours
17049	RF Supervisory Time	4 hours
17069	No Phone Line	0-Off
17072	Enable RF Jam Detect	1-On
17073	Automatic Panel Backup Battery Test Interval	1-4 hours
17076	Commercial/Residential	0-Off Residential
17078	Detect RF Receiver Failure	1-On
17079	Alarm Messages Play at High Volume	1-On High
17096	Report System Events	1-On
47004	#2-Supervisory Time Zone Attribute (all zones) #4-Hardwire Smoke Verify Zone Attribute	A (set to 4 hrs. in Feature 17049) 0-Of

xx = Two digit partition number.  
yy = Two digit non-pager phone number.

**Household Burglar-Alarm System Units (UL 1023)**

Basic system plus:

- Hardwire Magnetic Contact (13-068 or 13-071)

The basic system may also include:

- SuperBus 2000 Commercial RF Transceiver (60-821) for use with listed wireless signaling devices.
- Wireless Learn Mode Door/Window Sensor (60-362)
- SuperBus 2000 Printer or Automation Module

(60-783) for use with a listed printer.

- SuperBus 2000 Dual Phone Line Module (60-768) for expansion to primary and secondary phone line reporting.

#### System Setup and Programming

The system Feature Numbers shall be set as follows in UL 1023 listed systems:

**Table 4: UL 1023 Listed System Settings**

Feature No.	Feature	Required Setting
xx002	Siren Sound Time	6 min. minimum
xx003	Entry Delay	45 sec. maximum
xx004	Exit Delay	60 sec. maximum
yy004	Communication Format	0 Contact ID
xx088	Report Partition Events	1-On
xx092	Auto Forced Arming	0-Off
xx097	Exterior Siren Arming Verification	0-Off
xx102	Exit Delay Reset	0-Off
xx108	Local Trouble Annunciation at LTIME.	1-On
17036	AC Stable Time	90 sec. maximum
17041	AC Report Delay	6-12 hours
17049	RF Supervisory Time	4 hours
17069	No Phone Line	0-Off
17072	Enable RF Jam Detect	1-On
17073	Automatic Panel Backup Battery Test Interval	1-4 hours
17076	Commercial/Residential	0-Off Residential
17078	Detect Receiver Failure	1-On
17079	Alarm Messages Play at High Volume	1-On High
17096	Report System Events	1-On
47004	#2-Supervisory Time Zone Attribute (all sensors) #4-Hardwire Smoke Verify Zone Attribute	A (set to 4 hrs. in Feature 17049) 0-No

xx = Two digit partition number.  
yy = Two digit non-pager phone number.

#### Central Station Burglar-Alarm System Units (UL 1610)

Basic system using Commercial Burglary (60-562-01 or 60-562-04) Control Panel, plus:

- Hardwire Magnetic Contact (13-068 or 13-071).

The basic system may also include:

- SuperBus 2000 Commercial RF Transceiver (60-821) for use with listed wireless signaling devices.
- Wireless Learn Mode Door/Window Sensor (60-362).
- SuperBus 2000 Printer or Automation Module (60-783) for use with a listed printer.
- SuperBus 2000 Dual Phone Line Module (60-768) for

reporting to multiple phone lines.

#### System Setup and Programming

The system Feature Numbers shall be set as follows in UL 1610 listed systems:

**Table 5: UL 1610 Listed System Settings**

Feature No.	Feature	Required Setting
xx002	Siren Sound Time	16 min., minimum
xx003	Entry Delay	45 sec., maximum
xx004	Exit Delay	60 sec., maximum
yy004	Communication Format	0 Contact ID
xx088	Report Partition Events	1-On
xx092	Auto Forced Arming	0-Off
xx097	Exterior Siren Arming Verification	0-Off
xx098	Local Closing Report Verification	1-On
xx102	Exit Delay Reset	0-Off
xx108	Local Trouble Annunciation at LTIME.	1-On
17034	Auto Phone Test Frequency	1 Day
17036	AC Stable Time	90 sec. maximum
17041	AC Report Delay	6-12 hours
17049	RF Supervisory Time	4 hours
17069	No Phone Line	0-Off
17072	Enable RF Jam Detect	1-On
17073	Automatic Panel Backup Battery Test Interval	1-4 hours
17076	Commercial/Residential	1-Commercial
17078	Detect Receiver Failure	1-On
17079	Alarm Messages Play at High Volume	1-On High
17096	Report System Events	1-On
47004	#2-Supervisory Time Zone Attribute (all sensors) #4-Hardwire Smoke Verify Zone Attribute	A (set to 4 hrs. in Feature 17049) 0-No

xx = Two digit partition number.  
yy = Two digit non-pager phone number.

#### Digital Alarm Communicator System Units (UL 1635)

Same as UL 1610 plus:

- A UL Listed Exterior Siren.

#### Central Station Reporting

The panel has been tested with the following central station receivers using Contact ID reporting format:

- ITI CS-5000 Central Station Receiver.
- Sur-Gard Central Station Receiver with models SG-DRL2A and SG-CPM2.
- Radionics Model (D6600).

## California State Fire Marshall Listed Installations

The California State Fire Marshall listing has been approved.

## Planning the Installation

This section describes system capabilities to help you get familiar with the system. “Appendix A” provides planning sheets with tables that let you record the hardware and programming configuration of the system. Fill in all necessary information ahead of time to help prepare for the installation, and retain for your records.

**Note**

It is recommended that no more than 132 wireless sensors be used in any individual Advent system.

If 2 or more Advent systems are in close proximity to each other, the total number of wireless sensors for *all* systems must not exceed 132.

## Panel Types

To plan the installation, find your specific panel type below. The panel type will help determine the system capabilities (dependent upon devices used).

**Table 6: Advent Panel Types**

Part Number	Description	Partitions/Areas	Users	Input Zones
250Z, 60-562-01	Commercial Burglary Panel. UL Listings include 365, 609, 985, 1023, 1610 and 1635. Gray enclosure.	8	250	250
132Z, 60-562-04		4	100	132
250Z, 60-562-05	Home Nav Panel. UL Listings include 985, 1023 and 1635. White enclosure.	8	250	250
132Z, 60-562-02		4	100	132

## Panel Components

Before installing devices and making wiring connections, familiarize yourself with the main panel components. Figure 1 shows the main component locations for the circuit board.

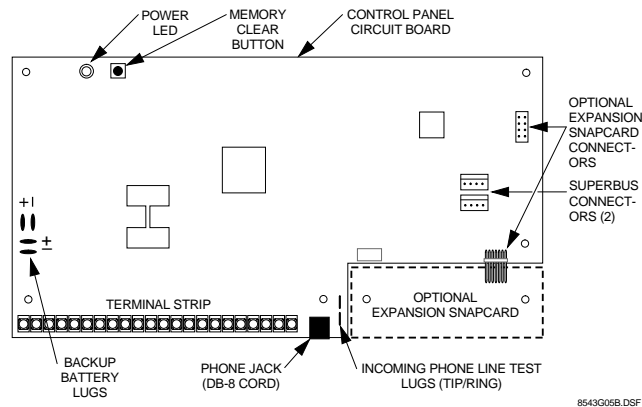

**Figure 1. Circuit Board Main Components**

## Panel Terminals

Table 7 describes each of the control panel terminals. Typical system wiring diagrams are provided on the last page of this manual.

**Note**

A) Class 2, Class 3, and power-limited fire alarm circuits must be installed using FPL, FPLR, FPLP, or substitute cable permitted by the National Electrical Code ANSI/NFPA 70. Wire that extends beyond the cable jacket must be separated from all other conductors by a minimum of 1/4-inch or by a nonconductive barrier.

OR

(B) Class 2, Class 3, and power-limited fire alarm circuit conductors must be installed as Class 1 or higher circuits.

**Table 7: Panel Terminal Strip Connections**

Terminal	Name	Used for
1	24 VAC	24 VAC, 100 VA power transformer connection.
2	24 VAC	24 VAC, 100 VA power transformer connection.
3	GND	Common ground connection for sirens, general purpose outputs 1-6, etc.
4	+12 VDC	Interior bell (+), and misc. DC power supply, 12 VDC @ 5.0A maximum load (includes Bus 1 and Bus 2 headers) Current limited.
5	INT BELL	Negative (-) side of bell connection. 12 VDC @ 150mA (sink) maximum. Positive (+) side to +12 VDC terminal 4. Connect multiple interior bells in parallel <sup>1</sup> .
6	EXT SIREN RTN	Negative (-) external siren drive return connection <sup>1</sup> .
7	EXT SIREN OUT	Positive (+) external siren power output connection. 30 VDC @ 2.5A maximum load <sup>1</sup> . Or 70 VAC @ 500 mA maximum.
8	EXT SIREN IN	Positive (+) external siren drive input connection. 30 VDC @ 2.5A or 70 VAC @ 500 mA maximum. Normally connected to +12 VDC terminal 4 or other siren voltage source <sup>1</sup> .
9	VOICE SIREN	One side of voice siren (speaker) connection. Other side to VOICE SIREN terminal 10 <sup>2</sup> .
10	VOICE SIREN	One side of voice siren (speaker) connection. Other side to VOICE SIREN terminal 9 <sup>2</sup> .
11	ZONE COM	Common return connection for general purpose inputs 1-7, sensors, etc.
12	GPI/O 1	General purpose hardwire input. GPI/Os 1-6 can be programmed for use as a hardwire contact input (2.0K ohm EOL resistor) or a control relay driver output (200 mA sink at 12 VDC maximum).
13	GPI/O 2	
14	GPI/O 3	
15	GPI/O 4	
16	GPI/O 5	
17	GPI/O 6	
18	INPUT 7	Hardwire input 7.
19	Unused	

**Table 7: Panel Terminal Strip Connections**

Terminal	Name	Used for
20	GND	Common ground
21	+SMOKE (+12VDC SW)	Positive (+) side of 2-wire, 12 VDC smoke loop. (Smoke and heat sensor DC power supply.) Switched 12 VDC @ 100 mA maximum (in alarm).
22	-SMOKE	Negative (-) side of 2-wire, 12 VDC smoke loop.
Backup Battery 1	+RED	Positive (+) side of panel backup battery one. 12V @ 1.6A source maximum. Source current limited.
	-BLACK	Negative (-) side of panel backup battery one.
Backup Battery 2	+RED	Positive (+) side of panel backup battery two. Source current limited.
	-BLACK	Negative (-) side of panel backup battery two.

1. For supplementary use only.  
2. Four to eight ohm maximum load between terminals 9 and 10.

### BUS Device Headers

Both bus device headers allow you to use SuperBus 2000 touchpads, modules, and devices. Each header can handle up to 31 devices for a total of 62 devices per panel. Table 8 describes the bus device headers.

**Table 8: BUS 1 and BUS 2 Headers**

Pin	Name	Used for
1 (Red)	+12V DC	SuperBus DC power supply. 12 VDC @ 650 mA maximum. Current limited.
2 (Green)	BUS A	SuperBus communication connection.
3 (White)	BUS B	
4 (Black)	GND	SuperBus common ground connection.

### Panel Devices

Devices that you can attach to the panel include SuperBus 2000 modules and SnapCards.

#### SuperBus 2000 Touchpads

The following touchpads provide complete system programming and operational control.

- ❑ **SuperBus 2000 2x20 LCD Touchpad:** Provides system programming and operation control. Large display shows system messages that prompt users for information when needed and indicates system status.
- ❑ **SuperBus 2000 2x20 VFD Touchpad:** Provides system programming and operation control. Large fluorescent display shows system messages that prompt users for information when needed and indicates system status.

#### SuperBus 2000 Modules

The following modules expand the system as described below:

- ❑ **SuperBus 2000 Commercial RF Transceiver Module:** The transceiver enables the use of wireless zones. When the transceiver is installed you may use a

combination of wireless and hardwire zones to reach the panel maximum.

- ❑ **SuperBus 2000 8Z Input Module (HIM):** Provides eight additional hardwire zone inputs.
- ❑ **SuperBus 2000 4-Relay Output Module (HOM):** Provides four form C relay outputs that can be set up to activate other signalling devices, based on system events.
- ❑ **SuperBus 2000 Dual Phone Line Module:** Allows for the use of two phone lines. In the event a primary phone line fails, a secondary line will be used.
- ❑ **SuperBus 2000 Printer Module:** Allows you to connect a printer to the panel.
- ❑ **SuperBus 2000 RS-232 Automation Module\*:** The SuperBus 2000 RS-232 Automation module allows you to connect an Advent panel to a compatible automation system. Once connected, the module will enable the automation system to interpret panel system status.
- ❑ **SuperBus 2000 LED Display Module (LED Driver Board)\*:** Uses LEDs to display system and devices status. Up to 16 SuperBus 2000 LED display or terminal boards may be connected to one driver board.
- ❑ **Voice Siren 25/70 Volt Converter Card\*:** Adds high voltage siren audio output capability.

### SnapCards

The following SnapCards expand the system as described:

- ❑ **8Z Input SnapCard:** Provides eight additional hardwire zone inputs, of which two are dedicated for using 2-wire smoke detectors (residential listings only).
- ❑ **4 Output SnapCard:** Provides four form C relay outputs that can be set up to activate other signalling devices, based on system events, schedules, or direct control.
- ❑ **4Z Input/2 Output Combo SnapCard:** Provides three hardwire zone inputs, one two wire smoke detector loop, and two outputs that can be set up to activate other signalling devices, based on system events, schedules, or direct control (residential listings only).

## Installing the System

This section describes how to install the system control panel. Before starting the installation, plan your system layout and programming using the worksheets provided in "Appendix A" on page 58.

Installing the system consists of the following:

- ❑ Determining the panel location (p. 6).
- ❑ Running wires to the panel location.
  - ❑ System wire lengths (p. 6).
- ❑ Mounting the panel (p. 7).
- ❑ Installing optional snapcards (p. 7).
- ❑ Connecting SuperBus 2000 modules and touchpads (p. 7).
- ❑ Connecting detection devices to panel zone inputs (p. 10).

\* Not investigated by UL.

- Connecting speakers (p. 11).
- Connecting sirens (p. 12).
- Installing an RJ-31X Phone Jack (p. 12).
- Connecting the phone line to the panel with a DB-8 cord (p. 13).
- Mounting/connecting an AC power transformer (p. 13).
- Installing the backup battery(s) (p. 14).
- Powering up the panel (p. 14).

### Determining the Panel Location

Before permanently mounting the panel, determine the panel location using the following guidelines:

- Centrally locate the panel in relation to detection devices whenever possible to help reduce wire run lengths and labor.
- Avoid running wires parallel with electrical wiring, or fixtures such as fluorescent lighting, to prevent wire runs from picking up electrical noise.
- Locate the panel where the temperature will not exceed 120°F (49°C) or fall below 32°F (0°C).
- If optional wireless transceiver module is used, avoid locations near excessive metal such as HVAC ducts, foil wallpaper, gas/water pipes, and electrical wiring.
- Mount the panel at a comfortable working height (about 45 to 55 inches from the floor to the bottom of the panel, as shown in Figure 2).
- Allow 6.5-inches to the right (or left) of the panel for wiring, phone jack, and optional module mounting.
- Allow at least 24-inches in front of the panel for access to panel components.

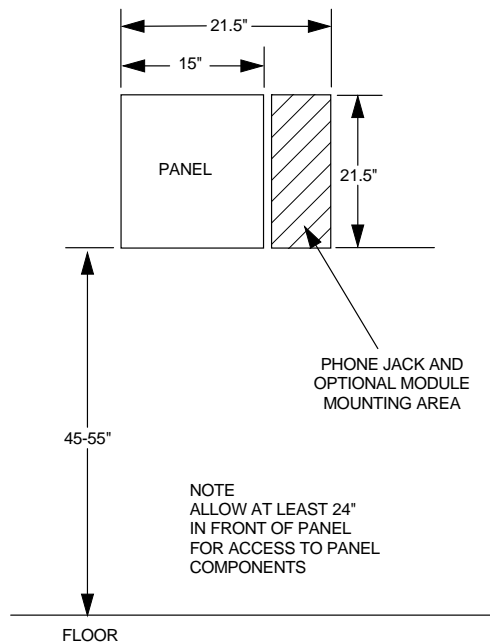

Figure 2. Determining Panel Location

### Running Wires to the Panel Location

Once you have determined the best possible panel location, run any necessary wires for the:

- power transformer,
- phone line(s),
- sirens/speakers,
- SuperBus 2000 alphanumeric touchpads,
- hardwired zones,
- output devices,
- Optional SuperBus 2000 modules (such as Dual Phone Line, Printer Modules, etc.).

### System Wire Lengths

The total system wire length allowed can vary depending on devices powered by the panel, the wire length between devices and the panel, and the combined wire length of all devices.

- Table 9 describes wiring recommendations for various panel components.

For devices where no recommended wire lengths are stated, or several devices share the same wire runs to the panel, please see Table A2 on page 57 to determine wire lengths based on current draw and resistance.

- Use 18-gauge wire for all commercial installations.
- Listed auxiliary power supplies may be used to reach the 4000ft maximum wire length for SuperBus modules. Please see Table A2 on page 57 to determine wire lengths based on the module(s) used.

Table 9: Wire Recommendations

Device	Max. Wire Length to Panel	Wire Type
AC Power Transformer	2-conductor, 18-gauge (located in cabinet)	Stranded
Earth Ground	Single conductor, 14-gauge, 25 feet maximum	Solid or Stranded
Telephone	Phone grade, 22-gauge	Solid or Stranded
Detection Devices	2- or 4-conductor, 22-gauge, 50-ohms resistance per zone including device	Stranded
Output Devices	18-gauge, 500 ft. maximum	Stranded
2-Wire Smoke Detectors	25-ohms per zone (including detection device resistance)	Stranded
Sirens, Piezos, and Speakers	2-conductor, 18-gauge, 500 feet maximum	Stranded
SuperBus 2000 2x20 LCD Alphanumeric Touchpad	22 ga.—500 ft. 18 ga.—1300 ft.	Stranded
SuperBus 2000 2x20 VFD Alphanumeric Touchpad	22 ga.—500 ft. 18 ga.—1300 ft.	Stranded
SuperBus 2000 Commercial RF Transceiver	22 ga.—1250 ft. 18 ga.—3000 ft.	Stranded



**Table 9: Wire Recommendations (Continued)**

Device	Max. Wire Length to Panel	Wire Type
SuperBus 2000 8Z Input Module	22 ga.—1750 ft. 18 ga.—4000 ft.	Stranded
SuperBus 2000 4-Relay Output Module	22 ga.—200 ft. 18 ga.—500 ft.	Stranded
SuperBus 2000 Dual Phone Line Module	22 ga.—350 ft. 18 ga.—900 ft.	Stranded
SuperBus 2000 Printer Module	22 ga.—1500 ft. 18 ga.—4000 ft.	Stranded
SuperBus 2000 RS 232 Automation Module*	22 ga.—1500 ft. 18 ga.—4000 ft.	Stranded
SuperBus 2000 LED Driver Board*	22 ga.—75 ft. 18 ga.—200 ft.	Stranded
4 Input/2 Output SnapCard	N/A	N/A
8Z Hardwire Zone Expander SnapCard	N/A	N/A
4 Output SnapCard	N/A	N/A

\* Not investigated by UL.

## Mounting the Panel

Use the following procedure to mount the panel to the wall or wall studs using the supplied mounting hardware and the panel mounting holes shown in Figure 3.

### CAUTION

Make sure you are free of static electricity whenever you work on the panel with the cover open. To discharge any static, first touch the metal panel chassis, then stay in contact with the chassis when touching the circuit board. Using an approved grounding strap is recommended.

1. Open the panel door and remove the panel circuit board, accessory kit, and packing material.
2. Put the circuit board from the packing in a safe static free location.
3. Remove the desired panel wiring knockouts.
4. Mount the optional key lock (if used) into the panel door.
5. Place the enclosure in position against the wall. Make sure enclosure is level and mark the locations of the two mounting holes and two keyhole mounting holes. Remember to leave room near the enclosure for any optional modules.
6. Use the appropriate mounting anchors and screws for your application. Partially insert screws into the two anchors at the two top keyhole locations, and then hang the panel chassis on the two screws.
7. Recheck level, insert the two lower screws, and then tighten all four mounting screws.
8. Route all wires to the panel.
9. Install the panel circuit board, using the five supplied board mounting screws.

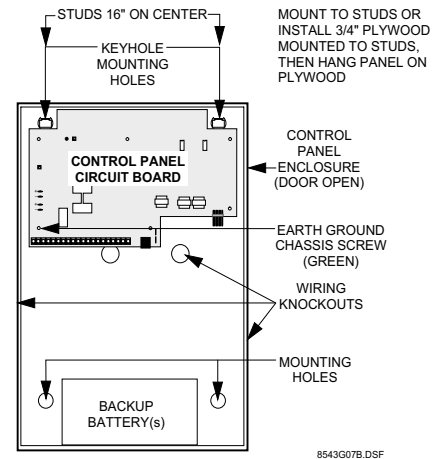

**Figure 3. Mounting the Panel and Circuit Board**

## Installing Optional Panel SnapCards

- ❑ 8Z Input SnapCard (60-757).
- ❑ 4 Output SnapCard (60-758).
- ❑ 4Z Input/2 Output Combo SnapCard (60-756).

The SnapCard Connectors shown in Figure 4 allow for the installation of two expansion SnapCards.

Carefully install a SnapCard onto the desired SnapCard Connector and secure it in place with the two screws included with the card.

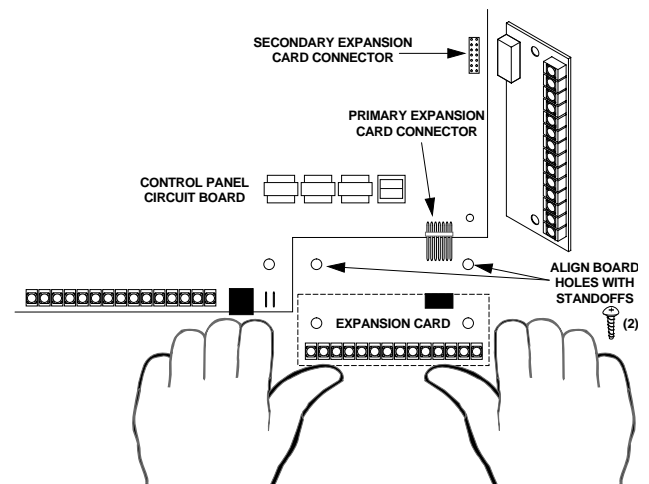

**Figure 4. Installing an Expansion SnapCard into one of the two SnapCard Connectors**

Connect all necessary input and/or output wiring using the *Installation Instructions* included with the SnapCard(s).

## Connecting SuperBus 2000 Modules and Touchpads

Up to 31 SuperBus 2000 devices (combinations of touchpads and modules) can be used on each of the two SuperBus connectors for a total of up to 62 devices. These modules connect to the panel via a 4-wire digital data bus and may

be located inside, next to, or away from the panel cabinet (see Figure 5). The panel cabinet may accommodate up to:

- ❑ 3 SuperBus 2000 input/output modules,
- ❑ 1 Voice Siren 25/70 Volt Converter Card,\*
- ❑ and 2 AC Power Transformers.

To wire SuperBus 2000 devices to the SuperBus connectors you must use the Panel SuperBus Wiring Harnesses (49-462) included with the accessory kit. You must splice all SuperBus 2000 module and touchpad wiring to the wires on these harnesses. Both SuperBus connectors are the same, and any combination of SuperBus devices (up to 31) may be wired to either connector. When all of the SuperBus 2000 devices are wired, plug each wiring harness into a SuperBus connector.

**Note**

The +12 VDC (RED) lead on the SuperBus wiring harness is current limited to 650 mA. If the total current draw for all devices on either SuperBus connector exceeds 650 mA, another power source must be used—such as Terminal 4 (+12V) or an external +\_12V power supply.

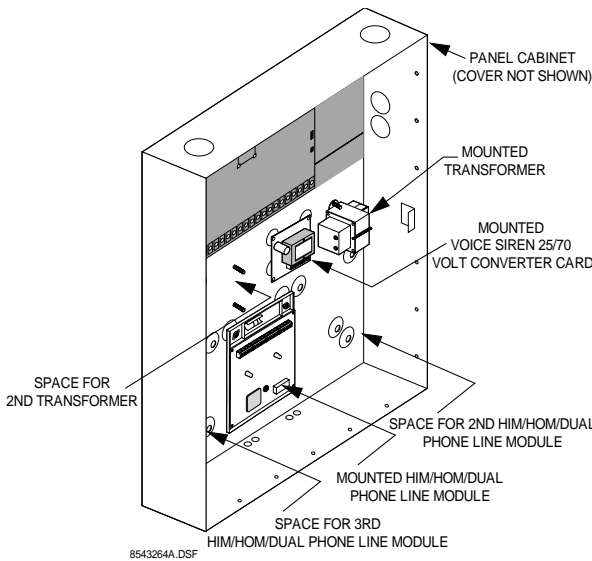

Figure 5. Mounting Devices in Panel Cabinet

**SuperBus 2000 Touchpads**

- ❑ 2x20 LCD Alphanumeric Touchpad (60-803-01).
- ❑ 2x20 VFD Alphanumeric Touchpad (60-804-01).

Connect SuperBus 2000 touchpads to the desired SuperBus connector as shown in Figure 6. For mounting instructions please see the specific touchpad *Installation Instructions*.

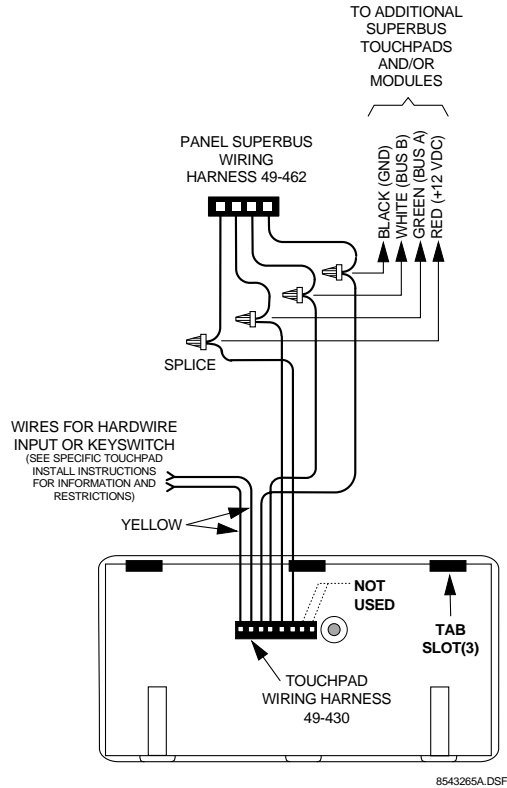

Figure 6. Connecting SuperBus 2000 Alphanumeric Touchpads

**SuperBus 2000 Modules**

**Commercial RF Transceiver Module**

- ❑ Commercial RF Transceiver Module in Plastic Case (60-821-95).

Connect the transceiver to the panel as shown in Figure 7.

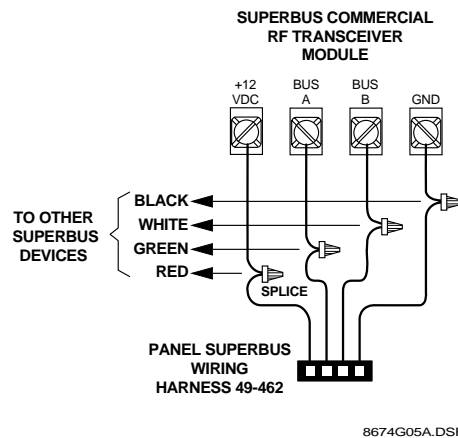

Figure 7. Connecting SuperBus 2000 Commercial RF Transceiver module

**8Z Input Module (60-774)**

Connect the SuperBus 2000 8Z Input Module to the panel as shown in Figure 8. Connect all necessary input wiring

\* Not investigated by UL.

using the *Installation Instructions* included with the module.

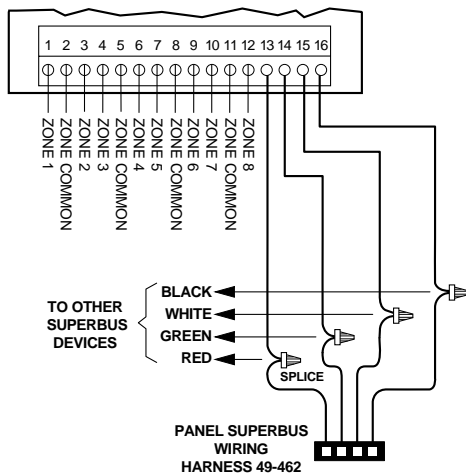

8543266A.DSF

Figure 8. Connecting a SuperBus 2000 8Z Input Module

#### 4-Relay Output Module (60-770)

Connect the SuperBus 2000 4-Relay Output Module to the panel as shown in Figure 9. Connect all necessary output wiring using the *Installation Instructions* included with the module.

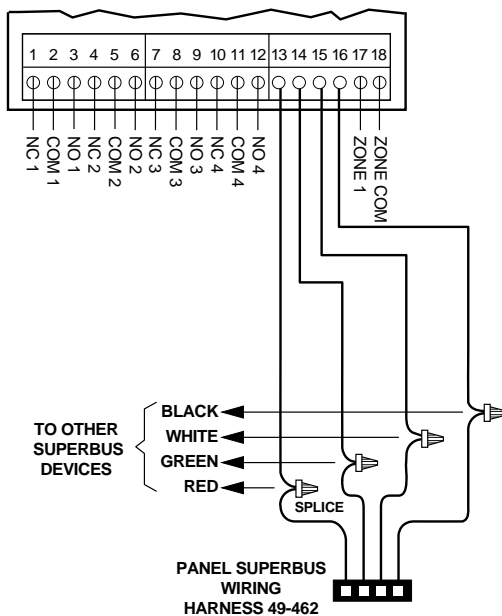

8543267A.DSF

Figure 9. Connecting a 4-Relay Output Module

#### Dual Phone Line Module (60-768)

Connect the SuperBus 2000 Dual Phone Line Module to the panel as shown in Figure 10. Connect all other phone wiring using the *Installation Instructions* included with the module.

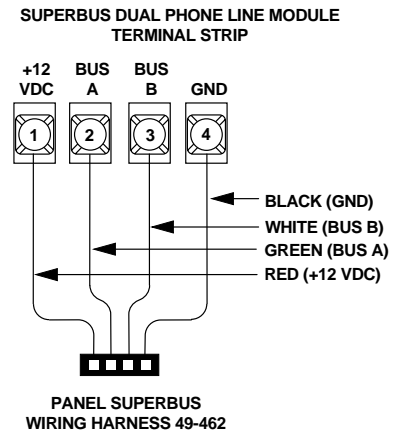

8844G05A.DSF

Figure 10. Connecting a SuperBus 2000 Dual Phone Line Module

#### Printer Module

- Printer Module in Plastic Case (60-783).

Connect the SuperBus 2000 Printer Module to the panel as shown in Figure 11. Connect all other printer wiring using the *Installation Instructions* included with the module.

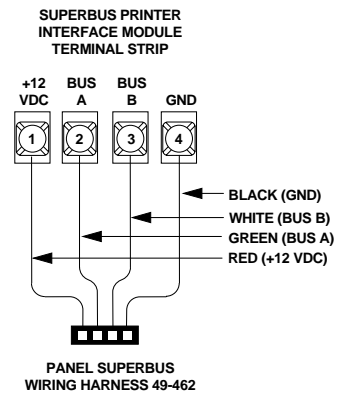

8543110A.DSF

Figure 11. Connecting a SuperBus 2000 Printer Module

#### RS-232 Automation Module\*

Connect the SuperBus 2000 RS-232 Automation Module to the panel as shown in Figure 12. For all other connections please see the module *Installation Instructions*.

\* Not investigated by UL.

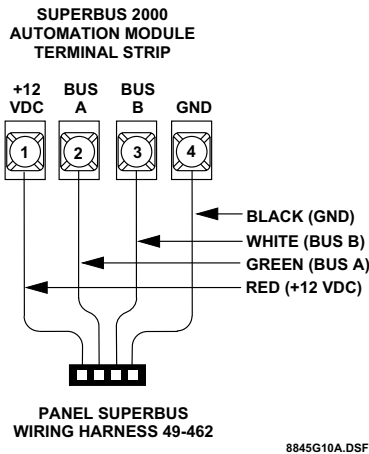

Figure 12. Connecting a RS-232 Automation Module

**Voice Siren 25/70 Volt Converter Card (60-773)\***

Mount the card in the panel cabinet in the area shown in Figure 5, and as described in the specific *Installation Instructions*. Wire the card to the panel and speakers as shown in Figure 14.

**Note**

70 volt wiring and supervision is shown. For 25 volt wiring, connect speakers to COMMON and 25V terminals, then jump +SUPERVISION to 25V terminal.

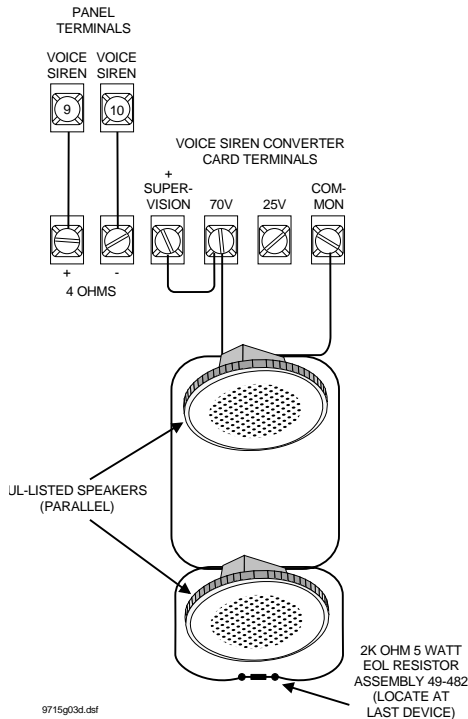

Figure 13. Connecting the Voice Siren 25/70 Volt Converter Card

\* Not investigated by UL.

**Note**

Separate in and out conductors must be used at each speaker. Do not loop a single wire around each terminal.

**Connecting Detection Devices to Panel Zone Inputs**

**Connecting Intrusion Detection Devices**

For information on programming and configuring detection devices, please see "Zone Settings" on page 22. For information on mounting and installing devices please see the *Installation Instructions* included with the device.

**General Inputs**

Figure 15 shows the typical wiring for N/C and N/O door/window intrusion detection.

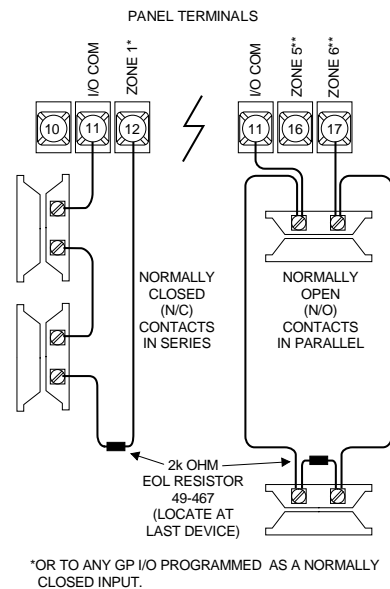

Figure 14. Installing Intrusion Detection Devices

**Connecting 2-Wire Smoke Detectors**

Panel terminals 21 and 22 are set up to accept the following 12 VDC 2-wire smoke detectors.

- System Sensor models 2100S, 2100TS, 2100D, 2100TD, 2400, or 2400TH.
- Sentrol (ESL) models 429AT, 521B, or 521BXT.

Panel terminals 21 and 22 can handle up to 20 smoke detectors with 120 uA maximum idle current per detector. Maximum total loop current allowed in alarm condition is 100 mA.

Connect one or more 2-wire smoke detectors to the panel as shown in Figure 16.

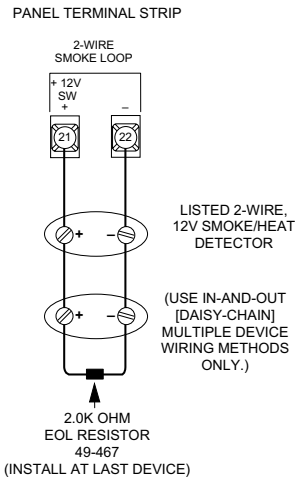

Figure 15. Connecting 2-Wire Smoke Detectors

### Connecting Speakers

The panel provides one speaker driver output for intrusion (steady), fire (temporal 3), and auxiliary (on-off-on-off) alarm sounds.

**Note**

The speaker output is used for partition/area 1 only.

The output can drive a single 8-ohm speaker or multiple speaker circuit of 4- to 8-ohms (as shown in the following speaker wiring diagrams). Comparable speakers are described below and on the following page.

**CAUTION**

To avoid damage to the panel speaker output, do not make speaker connections with the panel powered up.

#### 15-Watt Speaker (13-060) 30-Watt Speaker (13-061)

Use this speaker for interior siren applications such as status and voice. When wiring multiple speakers, the total impedance for all speakers must be between 4 and 8 ohms. Connect the speaker(s) to the panel as shown in Figure 16. For mounting instructions please refer to the *Installation Instructions* included with the speaker.

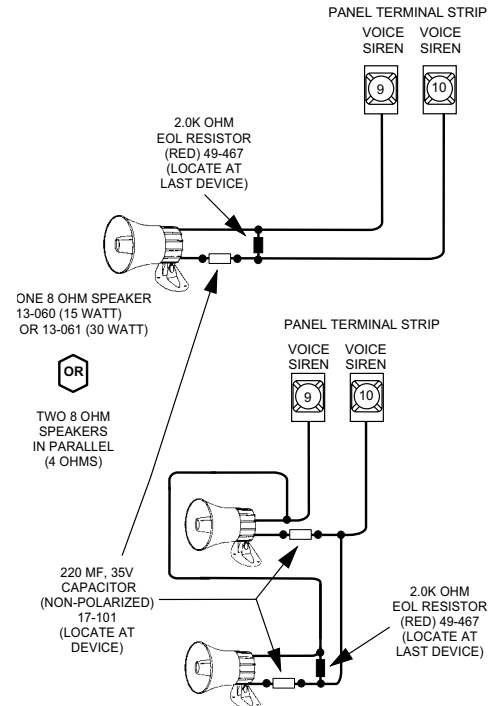

Figure 16. Connecting 15- and 30-Watt Interior Speakers

#### Hardwire Interior Speaker and Piezo (60-252)\*

Use this speaker for interior siren applications. Connect the speaker to the panel as shown in Figure 17. When wiring multiple speakers, stay between 4 and 8 ohms.

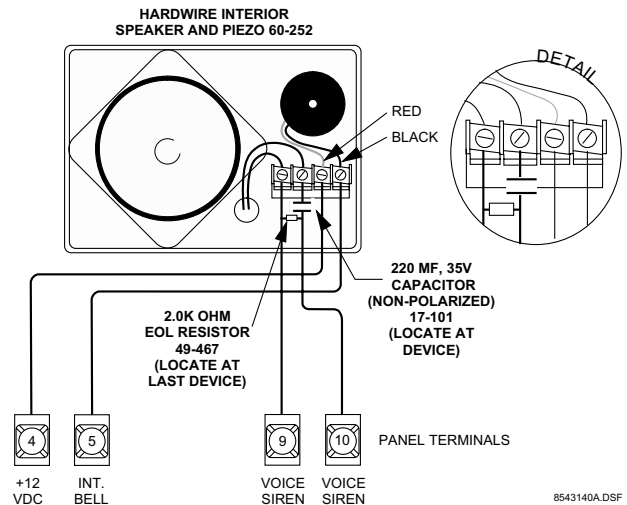

Figure 17. Connecting a Hardwire Interior Speaker and Piezo

#### Hardwire Interior Speaker (60-528)\*

Use this speaker unit for interior siren applications. Connect 1 speaker to the panel as shown in Figure 18. Connect multiple speakers to the panel as shown in Figure 19.

\* Not investigated by UL.

**CAUTION**

Connect only the large speaker to panel terminals 9 and 10 as shown. The smaller speaker cannot handle the output of terminals 9 and 10 and should not be connected to avoid damaging the speaker.

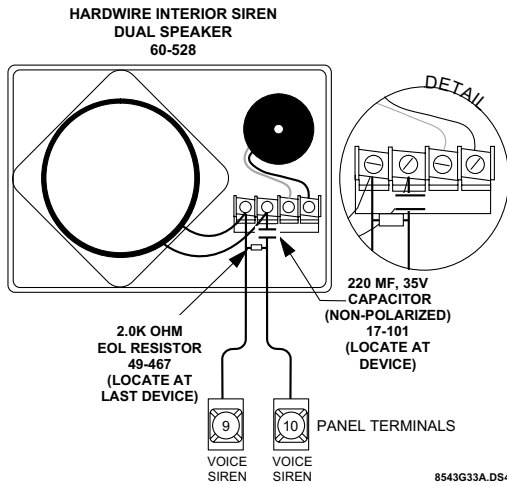

**Figure 18. Connecting the Hardwire Interior Speaker with Dual Speakers to the Panel**

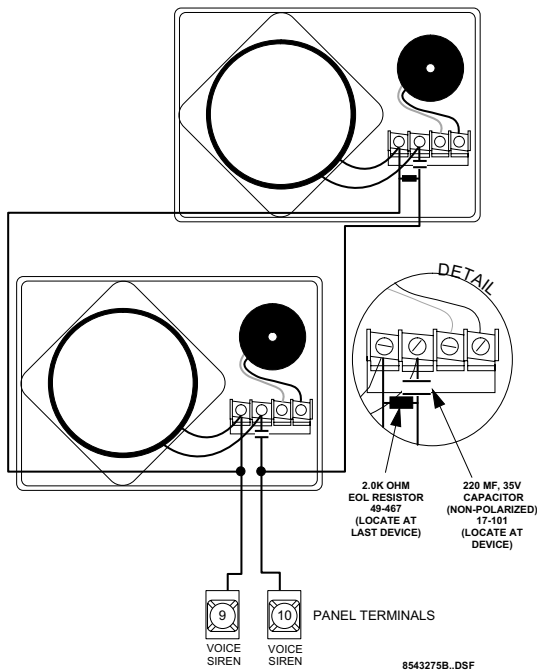

**Figure 19. Connecting Multiple Hardwire Interior Speakers w/Dual Speakers to the Panel**

**Connecting Listed Sirens**

Connect a listed exterior siren for partition/area 1 to the panel as shown in Figure 20. Interior and exterior sirens for other partitions/areas must be mapped to SnapCard, Super-Bus module or panel onboard outputs. Refer to program item 50005 on page 37.

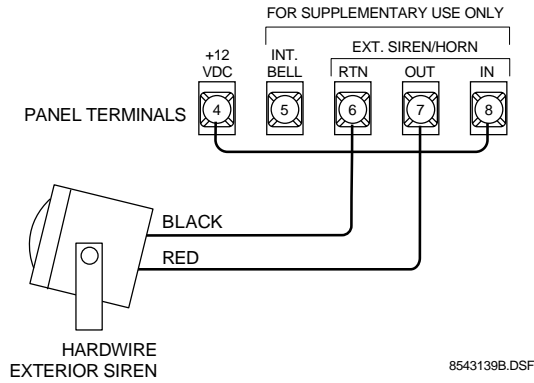

**Figure 20. Connecting the Hardwire Exterior siren to the Panel (partition/area 1)**

**Installing an RJ-31X Phone Jack (13-081)**

Use the following guidelines when installing an RJ-31X phone jack for system control by phone and central station monitoring.

- Locate the RJ-31X jack (CA-38A in Canada) no further than five feet from the panel.
- The panel must be connected to a standard analog (loop-start) phone line, that provides around 48 volts DC (on-hook or idle).

**Note**

The panel cannot be used on a digital or PBX phone line. These systems are designed for digital type devices only, operating anywhere from 5 volts DC and up. The panel uses an analog modem and does not have a digital converter, adapter, or interface to operate through such systems.

- For full line seizure, install an RJ-31X phone jack on the premises phone line so the panel is ahead of all phones and other devices on the line. This allows the panel to take control of the phone line when an alarm occurs, even if the phone is in use or off-hook.
- If an analog line is not available, contact your customer's telecommunications specialist and tell him/her you need an analog line off the phone switch (PBX mainframe) or a 1FB (standard business line).

**Note**

Connecting the panel to an analog line off the phone switch places the panel *ahead* of the phone system, preventing panel access from phones on the premises. However, the panel can still be accessed from off-site phones.

**To connect a phone line to the panel using an RJ-31X/CA-38A jack:**

1. Run a 4-conductor cable from the TELCO protector block to the jack location (see Figure 21).
2. Connect one end of the cable to the jack.
3. At the TELCO protector block, remove the premises phone lines (lines from phone jacks on premises) from the block and splice them to the black and white (or yellow) wires of the 4-conductor cable.
4. Connect the green and red wires from the 4-conductor cable to the A (+) and B (-) posts on the block (see Figure 21).

- If desired, add phone jack tamper by splicing the black and yellow phone jack wires to the panel terminals and adding a 2.0K ohm EOL resistor between the blue and orange phone jack terminals as shown in Figure 21.
- Check the phones on the premises for dial tone and the ability to dial out and make phone calls. If phones do not work correctly, check all wiring and correct where necessary. Proceed to “Troubleshooting” on page 50 if problems persist.

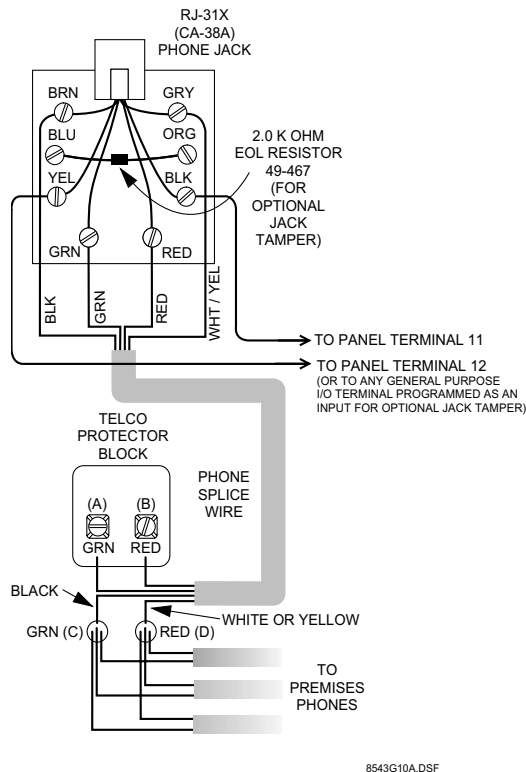

Figure 21. Installing an RJ-31X Phone Jack

## Connecting the Phone Line to the Panel with a DB-8 Cord (49-442)

After installing the RJ-31X jack, you are ready to connect the phone line to the panel.

**To connect the DB-8 cord to the panel terminals and RJ-31X jack:**

- Insert one end of the DB-8 cord plug into the RJ-31X (see Figure 22).
- Insert the other end of the DB-8 cord plug into the phone jack on the Advent panel circuit board (see Figure 22).

- Check the phones on the premises for dial tone and the ability to dial out and make phone calls. If phones do not work correctly, check all wiring and correct where necessary. Proceed to “Troubleshooting” on page 50 if problems persist.

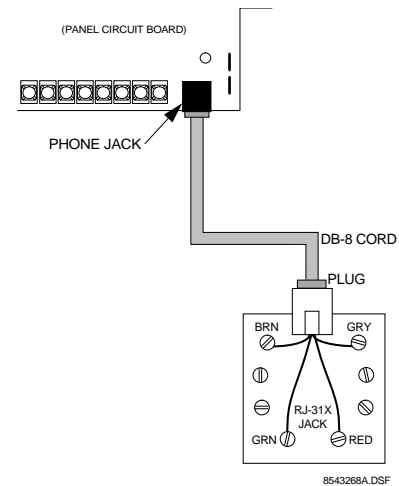

Figure 22. Connecting the DB-8 Cord to the Panel and RJ-31X Jack

## Mounting/Connecting an AC Power Transformer

Use the following AC power transformers with Advent panels:

- 24 VAC output, 100 VA Class I, 110VAC, 60 Hz (60-830).
- 24 VAC output, 100 VA Class II, 110VAC, 60 Hz (60-823) Line Carrier AC Power Transformer.

- Mount the transformer in the cabinet at one of the two locations shown in Figure 5.

### Note

Transformer load (secondary) terminals must face the center of the enclosure.

- Secure the transformer to the cabinet using the threaded standoffs and supplied hex nuts.
- Route the AC power transformer cord or wires through one of the knockouts.

### Note

The AC supply is non-power limited. It must be separated from all power limited wiring in the cabinet by at least 0.25" and wired using a separate knockout.

- Wire the AC power transformer to the panel as shown in Figure 23.

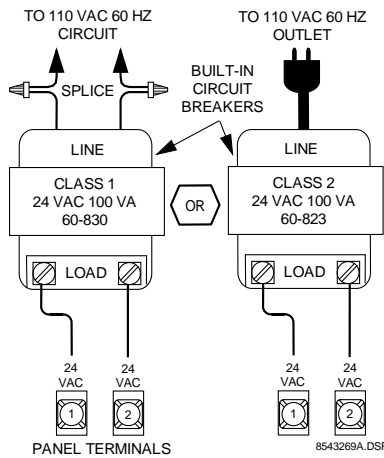

Figure 23. Wiring an AC Power Transformer to the Panel

## Installing Panel Backup Battery(s)

The panel uses from one to three rechargeable, sealed 12V lead-acid backup batteries (60-781).

**Note**

When replacing batteries, always replace with the same battery type and size.

**To install (or replace) backup battery(s):**

1. Make sure the panel AC power is off or disconnected.
- ⚠ **CAUTION**  
While AC power is applied to the panel, the charging voltage is present at the battery leads.
2. Verify all wiring at the panel and devices for correct terminations.
3. Place the battery in the lower left or right portion of the panel enclosure, with the terminals facing up.
4. Connect the black battery wire(s) from the panel circuit board negative (-) battery spade lug(s) (located on the left side of the board) to the negative (-) battery terminal (Figure 24).
5. Connect the red battery wire(s) from the panel circuit board positive (+) battery spade lug(s) to the positive (+) battery terminal.
6. On three battery installations, wire the third battery in parallel (positive to positive and negative to negative) with either of the two sets of battery spade lugs on the panel.

**⚠ WARNING**

Never short-circuit or reverse the battery wires. Possible injury to you and/or permanent damage to the panel and battery could result.

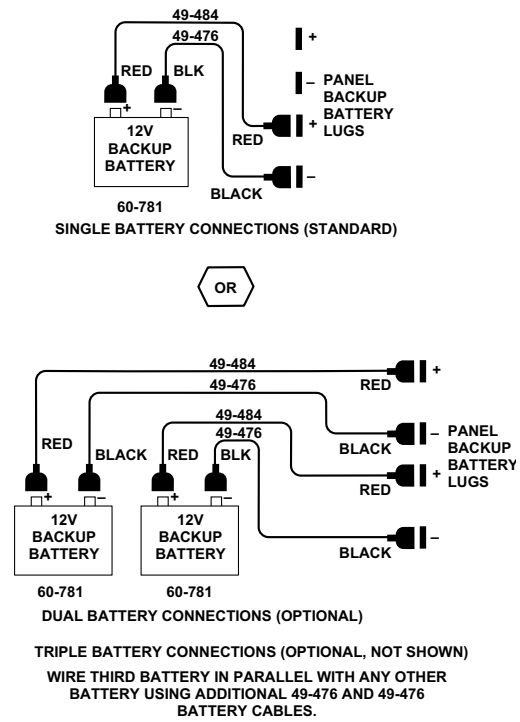

Figure 24. Connecting Backup Battery(s)

## Powering Up the Panel

After connecting and wiring all devices to the panel, you are ready to power up the panel.

**To power up the panel:**

1. If you have not already done so, connect the backup battery(s).
2. Depending on your transformer,
  - Plug the transformer into an outlet not controlled by a switch,
  - or apply power to the circuit which the transformer is connected to.
3. Wait about 30 seconds and note the following:
  - The green power LED (located on the circuit board) turns on and stays on.
  - Alphanumeric touchpads should display “PARTITION 1 SECURITY IS OFF.”

**Note**

If the power LED is off or flashing, or if touchpads don't display anything, remove panel power, disconnect the backup battery(s) and see “Troubleshooting” on page 48.

## Programming the Panel

The panel can be programmed using downloader software or an alphanumeric touchpad connected to the panel. The system interface is menu-driven and self-prompting. It will automatically request access codes and data if required.



## Using the Downloader Software to Program the Panel\*

With a personal computer, modem, phone cables, and ITI Advent Downloader software, you can quickly and efficiently download previously selected programming to the panel via a phone line connection. You can also upload panel programming to the software for your records or for “copying” to another similar installation.

For details on using the downloader software, refer to the *Advent Downloader User's Manual* shipped with the software.

For detailed instructions on preparing the panel for downloading, refer to “Remote Downloader Programming” on page 46.

## Using an Alphanumeric Touchpad to Program the Panel

In program mode, touchpad buttons let you navigate through installer programming menus for configuring the system. Table 10 describes the touchpad button functions in program mode.

**Table 10: Alphanumeric Touchpad Button Programming Functions**

Button	Programming Function
#	Confirms data entry.
*	Press to undo, cancel data/selection, or return to previous menu.
0 thru 9	Enter numeric values wherever needed.
0 & 1	Select off (0) or on (1) wherever needed.

### Entering/Exiting Program Mode

Entering program mode is done using an installer code. The system can only be placed in program mode when all partitions/areas are disarmed.

#### To enter program mode:

1. Make sure the system is disarmed in all partitions/areas.
2. At a touchpad, press 8 and the touchpad displays SYSTEM MENU.
3. Press 0 and the touchpad displays ENTER YOUR CODE.
4. Enter your INSTALLER ACCESS CODE (0123 is default) and the touchpad shows PROGRAM MENU then ENTER ITEM NUMBER. Enter the desired item number.

#### To exit program mode:

- Press \* repeatedly.

### Using Item Numbers

When prompted, entering an Item Number will “jump” you to the setting associated with the number. Once at the setting you may view or change setting attributes. After changing attributes press # to confirm, then you may exit programming (\*) or enter another item number.

\* Not investigated by UL.

Table 11 describes the setting type and range/description of all system item numbers.

**Table 11: Item Number Descriptions**

Setting Type	Range and Description
Partition/Area	xx001–xx125 (xx = partition 01–08)
Global/System	17001–17129
Phone Number	yy001–yy005 (yy = phone 19–24) zz001–zz016 (zz = phone/pager 25–40)
Zone Utilities	47001–47008
SuperBus Utilities	48001–48007, 48009–48010
Display Text Utilities	49001–49005
Miscellaneous Utilities	50001–50016

System settings are explained below and on the following pages. They appear as follows:

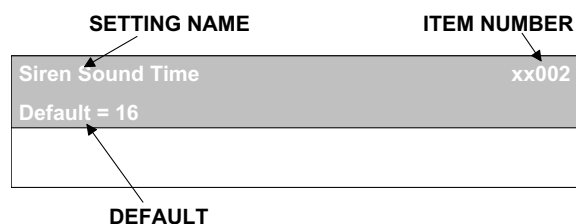

System settings in this manual appear in the same order as you would see them in Advent Downloader software. This is done to eliminate confusion whether you are programming from a touchpad or the downloader.

If you prefer, Table A14 in Appendix A lists the system settings in numerical order. Included in the table are the item number, default setting, and page number reference of the setting description.

#### Note

To keep track of panel programming, it is recommended that you enter item number settings in Table A14 in Appendix A.

### Special Programming Settings

Clear Panel Memory Default = NA	50002
It is recommended that you clear memory on all newly installed panels before programming. Clearing memory deletes setup values and resets all values to factory defaults.	
<b>To Clear Panel Memory:</b>	
<ol style="list-style-type: none"> <li>1. Enter program mode.</li> <li>2. Enter the installer code.</li> <li>3. Enter item number 50002.</li> <li>4. Press 99 and then #. Wait about a minute until touchpads return to their default displays.</li> </ol>	
<b>Note</b>	
Since all programming information is contained in memory, clearing memory deletes all existing programming information except dealer values (if any).	

**Reviewing (List) Settings** 00000  
**Default = NA**

An easy way of listing all programming settings and their values is provided. You can list *all* settings, or settings starting at a selected item number.

**To List *all* Settings:**

- Once in program mode enter the item number (00000).
- Press # to start listing settings from the beginning  
*or*  
 enter the item number you wish to start at and press #. Touchpads will flash each of the item numbers and values (if not protected by dealer password).
- Press \* at any time to exit this menu.

**Note**  
 Displayed setting values may be viewed but not changed using this procedure.

**General Settings**

**Areas** 17127  
**Default = 0 (Off)**

Choose whether or not to treat partitions as areas. If treated as areas:

- Zones, touchpads, schedules, programming options, etc., belong to areas instead of partitions.
- Users may “jump” from one area to another area using an alphanumeric touchpad.
- The word “partition” will be changed to “area” wherever it is spoken, displayed, or printed.

**To Turn Areas On/Off:**

Once the item number has been entered, enter 1 for on, or 0 for off. Press # to apply the new setting.

**Touchpad Return Time** 17035  
**Default = 10 Seconds**

This setting allows you to select the length (in seconds) of inactivity (no menu activity) before a “jumped” touchpad returns to its assigned area.

**To Set Touchpad Return Time:**

- Once in program mode enter the item number.
- Enter the desired length (5–60) and press #.

**Global Account Reporting** 17093  
**Default = 0 (Off)**

The setting enables the panel to report events as a system.

When set to on:

- The panel will use the system account when reporting) events. The area number where the event occurred is also reported.
- The panel will only perform one automatic phone test (not one for each partition/area).

**To turn Global Account Reporting On/Off:**

Once the item number has been entered, enter 1 for on, or 0 for off. Press # to apply the new setting.

**Partition/Area Enable** xx068  
**Defaults = Partition/Area 1— 1 (On), All Others— 0 (Off)**

Choose whether or not to enable the partition/area. Partition/Area 1 is always enabled.

**To Enable/Disable a Partition/Area:**

Once the item number has been entered, enter 1 for on, or 0 for off. Press # to apply the new setting.

**Account Number 1** xx116  
**Account Number 2** xx117  
**Defaults = 00000000**

Enter an 8 digit account number. Each partition/area may have two account numbers. Account number 1 will use the primary phone number to report partition/area events, while account number 2 will use the secondary phone number to report partition/area events.

Account Number Format:

<input type="checkbox"/> for 0 enter 00	<input type="checkbox"/> for 6 enter 06	<input type="checkbox"/> for C enter 12
<input type="checkbox"/> for 1 enter 01	<input type="checkbox"/> for 7 enter 07	<input type="checkbox"/> for D enter 13
<input type="checkbox"/> for 2 enter 02	<input type="checkbox"/> for 8 enter 08	<input type="checkbox"/> for E enter 14
<input type="checkbox"/> for 3 enter 03	<input type="checkbox"/> for 9 enter 09	<input type="checkbox"/> for F enter 15
<input type="checkbox"/> for 4 enter 04	<input type="checkbox"/> for A enter 10	
<input type="checkbox"/> for 5 enter 05	<input type="checkbox"/> for B enter 11	

**To Enter an Account Number:**

- Once the desired item number has been entered the current account number will be displayed.
- Enter the new account number using the list above. For example, if you wanted the account number to be “123456AB,” at the keypad you would enter “01, 02, 03, 04, 05, 06, 10, 11.”
- Press # and the touchpad displays the new account number.

**Note**  
 Account numbers must equal 8 characters. If you enter less than 8 characters the panel will automatically replace the blank spaces with leading zeros (0).

<b>Partition/Area Text</b> Default = None	<b>49004</b>
<p>Use the following guidelines to assign each partition/area a name.</p> <ul style="list-style-type: none"> <li><input type="checkbox"/> Use the item numbers that appear in Table B2 on page 85 for characters and words listed there.</li> <li><input type="checkbox"/> If a desired word does not appear in Table B2, create it using the characters (custom text).</li> <li><input type="checkbox"/> When using words from Table B2, spaces between them appear automatically. When using characters from Table B2 to create words, you must reserve an item number for a 'space' after the word.</li> <li><input type="checkbox"/> Each character or word uses up one item number. For example, a word from the list counts as one item number. A created word (such as BOY'S) counts as six item numbers—4 letters, 1 apostrophe, and 1 space.</li> <li><input type="checkbox"/> Only 8 item numbers are allowed for each partition/area name, so plan ahead before programming partition/area text. You may need to abbreviate words to avoid running out of item numbers.</li> </ul> <p><b>To Program Partition/Area Text:</b></p> <ol style="list-style-type: none"> <li>1. Once in program mode enter 49004. The display shows ENTER PARTITION NUMBER OR PRESS * TO CANCEL.</li> <li>2. Enter the desired partition number and press #. The display shows TEXT FOR PARTITION N IS CURRENT TEXT. ENTER TEXT NUMBERS OR PRESS # TO ACCEPT.</li> <li>3. Enter the numbers of the desired characters or words. If you make a mistake press * to start over.</li> <li>4. Once all numbers have been entered, press # to accept. The display shows the new partition/area text.</li> </ol> <p><b>To Delete Partition/Area Text:</b></p> <ol style="list-style-type: none"> <li>1. Once in program mode enter 49004. The display shows ENTER PARTITION NUMBER OR PRESS * TO CANCEL.</li> <li>2. Enter the desired partition/area number and press #. The display shows TEXT FOR PARTITION N IS CURRENT TEXT. ENTER TEXT NUMBERS OR PRESS # TO ACCEPT.</li> <li>3. Enter 000 and press #. The display shows TEXT FOR PARTITION N IS NO TEXT.</li> </ol>	

## Alarm Settings

<b>LTime</b> Default = 12:00	<b>xx001</b>
<p>This is the time of day when the system will annunciate any existing trouble conditions. For Advent Commercial Burglary panels, trouble(s) are annunciated every 4 hours. If the LTIME is set at 12:00 pm then the system will announce trouble(s) at 12:00 pm, 4:00 pm, 8:00 pm, 12:00 am, 4:00 am, and 8:00 am.</p> <p>For Advent Home Navigator panels, trouble(s) are annunciated every 24 hours (at LTIME).</p> <p><b>To Set the LTIME Sound Time:</b></p> <p>Once the item number has been entered, enter the 4-digit time (00:00–23:59) in 24 hour format and press #.</p> <p><b>Note</b> The Enable Daily Reporting of Partition/Area Trouble setting (xx108) must be set to "on" for this setting to work.</p>	

<b>Local Trouble Annunciation at LTime</b> Default = 1 (On)	<b>xx108</b>
<p>Enables annunciation of all trouble conditions at LTime.</p> <p><b>To set the Local Trouble Annunciation at LTIME:</b></p> <p>Once the item number has been entered, enter 1 for on, or 0 for off. Press # to apply the new setting.</p>	

<b>Siren Sound Time</b> Default = 16 Minutes (Commercial Burg) Default = 8 Minutes (Home Navigator)	<b>xx002</b>
<p>This is the number of minutes that the alarm siren is allowed to sound. The siren will silence when this value is reached.</p> <p><b>To Set Siren Sound Time:</b></p> <p>Once the item number has been entered, enter the number of minutes (01–30) you wish the siren to sound and press #.</p>	

<b>Exterior Siren Sounds Instantly</b> Default = 0 (Off)	<b>xx113</b>
<p>This setting allows you to set the delay (in seconds) before an exterior siren sounds during an alarm. This includes all high level alarms, except for auxiliary alarms, which don't sound exterior sirens. If set to on, exterior sirens sound instantly. If set to off, exterior sirens sound after a 15-second delay.</p> <p><b>Turning Exterior Siren Delay On/Off:</b></p> <p>Once the item number has been entered, enter 1 for on (15-second delay), or 0 for off (no delay). Press # to apply the new setting.</p>	

<b>Zone Tamper Alarm Enable</b> Default = 0 (Off)	<b>xx079</b>
<p>This setting determines whether a tamper alarm is generated for a zone that is not armed (applies to non-fire zones only). If on, a zone tamper alarm is generated when a zone tamper is detected in any arming level. If off, an alarm is only generated when the zone is in an active level.</p> <p><b>Turning Zone Tamper Report Enable On/Off:</b></p> <p>Once the item number has been entered, enter 1 for on (alarm in all levels), or 0 for off (alarm in active levels). Press # to apply the new setting.</p>	

<b>Fire Tamper Response</b> Default = 0 (Off)	<b>xx083</b>
<p>This setting enables the panel to generate a tamper alarm (in addition to a trouble report) when tampering of a fire zone is detected.</p> <p><b>Setting Fire Tamper Response to On/Off:</b></p> <p>Once the item number has been entered, enter 1 for on (alarm is generated) or 0 for off (alarm not generated). Press # to apply the new setting.</p>	

**Keypad Tamper** xx076  
**Default = 0 (Off)**

This setting enables keypad tamper. When on, the panel will generate a police alarm when it detects four or more incorrect access code entry attempts that do not include a valid access code. A tamper report is also sent to the central station.

**Turning the Keypad Tamper Setting On/Off:**

Once the item number has been entered, enter 1 for on (generate alarm and report) or 0 for off. Press # to apply the new setting.

**No Activity Internal** xx009  
**Default = 0 (Not Active)**

This setting allows you to select the length of time (in hours) the panel will wait after not detecting any activity before initiating a no-activity pre-alarm. Once a no-activity pre-alarm is initiated the panel will wait until the time in the *No Activity Report Delay* setting (xx010) expires before generating an alarm.

**Setting the No Activity Internal Time:**

- Once the item number has been entered, enter the number of hours (1–24) you wish the panel to wait before initiating a no-activity pre-alarm, or 0 for not active.
- Press # to apply the new setting.

**No Activity Report Delay** xx010  
**Default = 5 Minutes**

This setting allows you to select the length of time (in minutes) allowed *after* the *No Activity Tripped* setting (xx009) time has expired. If no activity is detected during this time the panel sends a report to the central station. If the user(s) generate activity within this delay period no report will be sent.

**Setting the No Activity Report Time:**

Once the item number has been entered, enter the number of minutes (1–10) you wish the panel to wait before sending a report. Press # to apply the new setting.

**Note**  
 If the No Activity Tripped After setting (xx009) is set to 0 (not active) this setting will have no affect.

**Generate Alarm for Suspicion Trips** xx078  
**Default = 1 (On)**

This setting allows you to enable the panel to generate a suspicion trip alarm. If on, and suspicion zones are tripped, an alarm will be generated after the Suspicion Alarm Delay (xx015) expires. If off, the tripping of suspicion zones will not generate an alarm.

**To Turn Generate Alarm for Suspicion Trips On/Off:**

Once the item number has been entered, enter 1 for on or 0 for off. Press # to apply the new setting.

**Suspicion Alarm Delay** xx015  
**Default = 05 Minutes**

Select the length of time in minutes in which an alarm can be avoided after a suspicion zone is tripped. This allows the user time to prevent a false alarm from being generated.

**Programming the Suspicion Alarm Delay:**

Once the item number has been entered, enter the number of minutes (1–15) you wish the panel to wait before going into alarm. Press # to apply the new setting.

**Note**  
 If the Generate Alarm Suspicion Trips setting (xx078) is set to off, this setting will have no effect.

**First Trip Local Second Trip Report** xx080  
**Default = 0 (Off)**

If on, the first zone trip in a two trip zone type (18 or 77) causes a local police alarm. A second zone trip from a different zone, occurring within four minutes of the first zone trip, generates a report. Zones must reside in the same partition/area. If off, the first zone trip starts a timer and the second zone trip causes the alarm and report.

**To Turn This Setting On/Off:**

Once the item number has been entered, enter 1 for on or 0 for off. Press # to apply the new setting.

**X-10 and Non-X-10 Output Settings**

**X-10 House Code 1** xx022  
**Default = Partition/Area Number**

The house code is a number from 1 to 16 (representing A–P) used to communicate panel signals to line carrier devices such as X-10 Lamp, Appliance, and Universal Modules. You can have up to two house codes per partition/area.

Enter the panel house code setting used for the first 16 X-10 line carrier devices. The system commands “All Lights On/Off” or “All Units On/Off” control only modules with House Code 1 (within respective partition/area). See Table B4 and B5 on page 90 for information on defaults.

**Entering House Code 1:**

Once the item number has been entered, enter the desired house code (1–16). Press # to apply the new setting.

**X-10 House Code 2** xx023  
**Default = Partition/Area Number + 8**

Enter the panel house code setting used for the last 16 X-10 line carrier devices within respective partition/area. See Table B4 and B5 on page 91 for information on defaults.

**Entering House Code 2:**

Once the item number has been entered, enter the desired house code (1–16). Press # to apply the new setting.

Non X-10 Output 1 (menu output 33)	xx049
Non X-10 Output 2 (menu output 34)	xx050
Non X-10 Output 3 (menu output 35)	xx051
Non X-10 Output 4 (menu output 36)	xx052
Non X-10 Output 5 (menu output 37)	xx053
Non X-10 Output 6 (menu output 38)	xx054
Non X-10 Output 7 (menu output 39)	xx055
Non X-10 Output 8 (menu output 40)	xx056
Default = 0 (None)	

There are 40 menu outputs per partition/area. The first 32 are X-10 outputs, the last 8 are non X-10 outputs. All X-10 outputs (menu outputs 1-32) are automatically linked to X-10 devices. Non X-10 outputs (menu outputs 33-40) must be linked to a programmable output in order to control a light or device.

**Note**

All menu outputs must be programmed (learned) into the panel before they will function. See "Programmable Output Settings" on page 36 for more information.

**Linking Non X-10 Outputs:**

1. Enter the item number for the desired non X-10 output.
2. Enter the desired programmable output number (1–100), then press # to confirm the selection.

Light Access Code Enable	xx069
Default = 0 (Off)	

If on, users must enter a valid access code before controlling lights. If off, an access code is *not* required for light control.

**Turning Light Access Code On/Off:**

Once the item number has been entered, enter 1 for on (access code required), or 0 for off. Press # to apply the new setting.

Device Access Code Enable	xx070
Default = 0 (Off)	

If on, users must enter a valid access code before controlling devices. If off, an access code is *not* required for device control.

**Turning Device Access Code On/Off:**

Once the item number has been entered, enter 1 for on (access code required) or 0 for off. Press # to apply the new setting.

Latchkey Access Code Enable	xx071
Default = 0 (Off)	

If on, users must enter a valid access code before accessing the Latchkey setting. If off, an access code is *not* required to access the Latchkey setting. For more information on Latchkey, please see the *User's Manual*.

**Turning Latchkey Access Code On/Off:**

Once the item number has been entered, enter 1 for on (access code required) or 0 for off. Press # to apply the new setting.

## Reporting Settings

Report Partition/Area Events	xx088
Default = 1 (On)	

If on, the panel will report partition/area events to the central station.

**Turning Partition/Area Event Reporting On/Off:**

Once the item number has been entered, enter 1 to turn partition/area event reporting on or 0 turn reporting off. Press # to apply the new setting.

Cancel Event Cancels Report	xx089
Default = 1 (On)	

If on, the panel will cancel the sending of an alarm report (to central station) if the event is canceled before the alarm reporting delay (xx013, xx012, or xx014) expires.

**Turning Cancel Event Cancels Report On/Off:**

Once the item number has been entered, enter 1 to turn the setting on (canceled event cancels report) or 0 to turn it off. Press # to apply the new setting.

Print Partition/Area Events	xx091
Default = 1 (On)	

If on, the panel will print partition/area events on a local printer.

**To Print Partition/Area Events:**

Once the item number has been entered, enter 1 (on) to enable printing of partition/area events or 0 (off) to disable printing of partition/area events. Press # to apply the new setting.

Panic Report Delay	xx012
Default = 05 Seconds	

This setting allows you to specify the length of time (in seconds) between the time a panic alarm condition is detected, and a panic report is sent to the central station. This allows users time to cancel the report of a false alarm if setting xx089 is on.

**Specifying the Panic Report Delay:**

Once the item number has been entered, enter the number of seconds (1–120) you wish the panel to wait before sending a panic report. Press # to apply the new setting.

Alarm Report Delay	xx013
Default = 05 Seconds	

This setting allows you to specify the length of time (in seconds) between the time a non-panic and non-fire alarm condition is detected, and a report is sent to the central station. This allows users time to cancel the report of a false alarm if setting xx089 is on.

**Specifying the Alarm Report Delay:**

Once the item number has been entered, enter the number of seconds (1–120) you wish the panel to wait before sending a report. Press # to apply the new setting.

**Fire Report Delay** xx014  
**Default = 0 Minutes**

This setting allows you to specify the length of time (in minutes) between the time a fire alarm condition is detected, and a report is sent to the central station. This allows users time to cancel the report of a false alarm if setting xx089 is on.

**Specifying the Fire Report Delay:**

Once the item number has been entered, enter the number of minutes (0–15) you wish the panel to wait before sending a report. Press # to apply the new setting.

**Second Fire Alarm Ends Reporting Delay** xx090  
**Default = 1 (On)**

If on, and a fire report delay is in progress, a second fire alarm condition will end the fire report delay (xx014) immediately sending a report to the central station.

**Programming Second Fire Alarm Ends Reporting Delay:**

Once the item number has been entered, enter 1 to turn the setting on (second alarm ends delay) or 0 to turn it off. Press # to apply the new setting.

**Second Intrusion Causes Report** xx077  
**Default = 0 (Off)**

If on, the first trip of an intrusion zone causes a local police alarm. A second trip (different intrusion zone) within four minutes generates a report. If off, the first trip of an intrusion zone generates both an alarm and report.

**Setting Second Intrusion Causes Report:**

Once the item number has been entered, enter 1 to turn the setting on or 0 to turn it off. Press # to apply the new setting.

**All Restoral Reports** xx112  
**Default = 0 (Off)**

If on, restoral reports are generated for all reporting zone types (which require restoral). If off, the zone type definition dictates whether on not a restoral report is generated.

**Turning All Restoral Reports On/Off:**

Once the item number has been entered, enter 1 to turn the setting on or 0 to turn it off. Press # to apply the new setting.

**Local Closing Report Verification** xx098  
**Default = 0 (Off)**

When on, the panel will locally verify that a closing report has been sent to the central station with an audible signal.

**Note**  
 In order for this setting to work, Exterior Siren Verification setting (xx097) must be set to "on."

**To Turn Local Closing Report Verification On/Off:**

Once the item number has been entered, enter 1 to turn the setting on or 0 to turn it off. Press # to apply the new setting.

**Arming Settings**

**Enable Level 2 Arming** xx025  
**Enable Level 3 Arming** xx026  
**Enable Level 4 Arming** xx027  
**Enable Level 5 Arming** xx028  
**Defaults = 1 (On)**

If on, the selected arming level will be enabled (level 1 is always enabled) in the selected partition/area. Users will then have access to this arming level. An arming level is the degree of security protection set at the panel.

**To Enable Arming Level:**

Once the item number has been entered, enter 1 to turn the setting on (level enabled) or 0 to turn it off. Press # to apply the new setting.

**Default Keyfob/Schedule Arming Level** xx118  
**Default = 3**

This setting allows you to select the arming level (2–5) the panel arms to when armed by a keyfob or schedule (auto arming).

**Specifying Keyfob/Schedule Arming Levels:**

Once the item number has been entered, enter the keyfob/scheduled arming level (2–5). Press # to apply the new setting.

**Default Keyswitch Arming Level** xx120  
**Default = 3**

This setting allows you to select the arming level (2–5) the panel arms to when armed by a keyswitch.

**Specifying Keyswitch Arming Levels:**

Once the item number has been entered, enter the keyswitch arming level (2–5). Press # to apply the new setting.

**Activity Fault Threshold 1** xx018  
**Activity Fault Threshold 2** xx019  
**Activity Fault Threshold 3** xx020  
**Defaults:**  
**Threshold 1 = 10, Threshold 2 = 30, Threshold = 50**

This setting allows you to specify the number of disarms without any activity before zone activity trouble is generated.

**Specifying Activity Fault Thresholds:**

Once the item number has been entered, enter the number of disarms before zone activity trouble is generated (2–255). Press # to apply the new setting.

**Enable Scheduled Arming** xx094  
**Default = 1 (On)**

This setting allows you to select whether or not to allow the system to arm/disarm according to a schedule.

**Turning Enable Scheduled Arming On/Off:**

Once the item number has been entered, enter 1 to enable scheduled arming or 0 to turn it off. Press # to apply the new setting.

**Scheduled Arming Period** xx007  
 Default = 10 Minutes

This is the amount of time between the start of arming notification and when the partition/area is armed by a schedule (auto arming). This notifies users that a scheduled arm is about to occur and allows time for users to vacate the premises.

**To Set the Scheduled Arming Period:**

Once the item number has been entered, enter the number of minutes (05–30) that will pass between notification and arming. Press # to apply the new setting.

**Scheduled Arming Extension** xx008  
 Default = 30 Minutes

This is the amount of time by which a scheduled arming period will be suspended during the arming notification period. For example, let's say the extension is entered when there is four minutes left in the delay. Once the extension has expired the system will start counting down the remaining four minutes.

**To Set the Scheduled Arming Extension:**

Once the item number has been entered, enter the number of minutes (15–120) users will be able to extend the notification period and press #.

**Auto Forced Arming** xx092  
 Default = 1 (On)

If on, any protesting zone(s) will be bypassed upon arming. If off, then the partition/area will not arm if *any* zone(s) are protesting.

**To Turn Auto Forced Arming On/Off:**

Once the item number has been entered, enter 1 to turn the setting on or 0 to turn it off. Press # to apply the new setting.

**Quick Arm** xx093  
 Default = 1 (On)

If on, anyone can arm the panel and increase arming levels without an access code. A valid access code is still required to decrease arming levels or disarm the system. Quick arm works as follows:

- |                                                 |                                                 |
|-------------------------------------------------|-------------------------------------------------|
| <input type="checkbox"/> Level 3 to 5 = no code | <input type="checkbox"/> Level 1 to 2 = no code |
| <input type="checkbox"/> Level 3 to 4 = code    | <input type="checkbox"/> Level 1 to 3 = no code |
| <input type="checkbox"/> Level 4 to 3 = no code | <input type="checkbox"/> Level 1 to 4 = no code |
| <input type="checkbox"/> Level 5 to 3 = code    | <input type="checkbox"/> Level 1 to 5 = no code |

**To Turn Quick Arming On/Off:**

Once the item number has been entered, enter 1 to turn the setting on or 0 to turn it off. Press # to apply the new setting.

**Exterior Siren Arming Verification** xx097  
 Default = 0 (Off)

If on, exterior sirens will produce arming verification sounds notifying users that the system was armed.

**Note**

In order for this setting to work, Local Closing Report Verification setting (xx098) must be set to "on."

**To Turn Exterior Siren Arming Verification On/Off:**

Once the item number has been entered, enter 1 to turn the setting on or 0 to turn it off. Press # to apply the new setting.

**Bypass Limit** xx017  
 Default = 250/132 (all zones)

Select the number of zones that may be bypassed at once. See Table B1 on page 80 for information on which zone types may be bypassed.

**To Program Bypass Limit**

Once the item number has been entered, enter the number of zones that may be bypassed at once (0–250). Press # to apply the new setting.

**Automatic Unbypass Enable** xx096  
 Default = 0 (Off)

If on, an indirectly bypassed zone will automatically be unbypassed once the door, window, etc., has been closed for 30 seconds. This setting only applies to delayed zones.

**To Turn Automatic Unbypass Enable On/Off:**

Once the item number has been entered, enter 1 to turn the setting on or 0 to turn it off. Press # to apply the new setting.

**Swinger Bypass Enable** xx095  
 Default = 1 (On)

If on, a zone that exceeds the set swing count (xx021) during a single arming period will automatically be bypassed. Changing the arming level restores all automatically bypassed zones and resets the swing count.

**To Turn Swinger Bypass Enable On/Off:**

Once the item number has been entered, enter 1 to turn the setting on or 0 to turn it off. Press # to apply the new setting.

**Swing Count (Auto Bypass Trips)** xx021  
 Default = 3

Select the maximum number of report attempts that one zone can generate during a single arming period before the panel automatically bypasses that zone.

All automatically bypassed zones, and the swing count, will reset if the system clock reaches midnight or an arming level change occurs.

**To Set the Swing Count:**

Once the item number has been entered, enter the desired swing count (1–8) and press # to apply the new setting.

**Entry Delay** xx003  
**Default = 32 Seconds**

Enter the length of the standard entry delay (in seconds). This is the number of seconds the user has to disarm the system after tripping a standard delay zone. If the system isn't disarmed within this time period an alarm is generated.

**Setting the Entry Delay:**

Once the item number has been entered, enter the number of seconds (24–120) users will have to disarm the system. Press # to apply the new setting.

**Exit Delay** xx004  
**Default = 32 Seconds**

Enter the length of the standard exit delay (in seconds). This is the number of seconds the user has to exit the premises through a standard delay door after arming the system. If the user trips a zone after this time period has expired, an alarm is generated.

**Setting the Exit Delay:**

Once the item number has been entered, enter the number of seconds (24–120) users will have to exit the premises after arming the system. Press # to apply the new setting.

**Extended Delay** xx005  
**Default = 2 Minutes**

Enter the length of the extended delay. The extended delay time determines how much time (in minutes) the user has to enter or exit the premises through an *extended* delay door without causing an alarm.

**Setting the Extended Delay:**

Once the item number has been entered, enter the number of minutes (1–10) for the extended delay and press #.

**Exit Delay Termination** xx101  
**Default = 0 (Off)**

If on, the system will arm as soon as it detects a delay zone closing. Once a person leaves through an exit delay door and the door closes, the exit delay is terminated and the system is armed.

**Note**  
 Cannot be used with Exit Delay Reset setting (xx102).

**To Turn Exit Delay Termination On/Off:**

Once the item number has been entered, enter 1 to turn the setting on or 0 to turn it off. Press # to apply the new setting.

**Exit Delay Reset** xx102  
**Default = 0 (Off)**

If on, the system will allow a one-time reset of the standard exit delay. If a user leaves through a delay door and the door closes, they may re-enter through the door within the exit delay time period and the system will reset the exit delay.

**Note**  
 Cannot be used with *Exit Delay Termination* setting (xx101).

**To Turn Exit Delay Reset On/Off:**

Once the item number has been entered, enter 1 to turn the setting on or 0 to turn it off. Press # to apply the new setting.

**Fast Beep Duration** xx006  
**Default = 10 Seconds**

Enter the length of time (in seconds) that fast beeps will sound during the last portion of the exit delay to signal the delay is ending.

**Setting the Fast Beep Duration:**

Once the item number has been entered, enter the number of seconds (5–15) fast beeps will sound before the end of the delay and press #.

**Exit Beeps only at end of Exit Delay** xx100  
**Default = 1 (On)**

If on, only the fast beeps at the end of the exit delay will sound. If off, slow exit delay beeps will sound followed by the fast beeps at the end of the delay.

**To Turn Exit Delay Beeps On/Off:**

Once the item number has been entered, enter 1 to turn the setting on or 0 to turn it off. Press # to apply the new setting.

**Entry Delay Beeps** xx103  
**Default = 0 (Off)**

If on, beeps only sound during the standard entry delay. If off, beeps sound during all segments of an entry delay including standard, extended, and twice extended.

**To Turn Entry Delay Beeps On/Off:**

Once the item number has been entered, enter 1 to turn the setting on or 0 to turn it off. Press # to apply the new setting.

**Zone Settings**

**Chime Text** xx110  
**Default = 0 (Off)**

If on, zone text will be announced over speakers and displayed on touchpads whenever a chime sounds (the sensor is open or closed). See Table B1 on page 79 for the zone types that chime.

**Note**  
 Only partition/area 1 has voice capabilities.

**To Turn Chime Text Setting On/Off:**

Once the item number has been entered, enter 1 to turn the setting on or 0 to turn it off. Press # to apply the new setting.



**Close Chime** xx111  
Default = 0 (Off)

If on, a chime will sound whenever a zone is restored. See Table B1 on page 79 for the zone types that chime.

**To Turn Close Chime Setting On/Off:**

Once the item number has been entered, enter 1 to turn the setting on or 0 to turn it off. Press # to apply the new setting.

**Zone Test Time Out** xx011  
Default = 30 Minutes

Enter the length of time (in minutes) after which a zone test automatically times out (ends).

**Setting the Zone Test Time Out:**

Once the item number has been entered, enter the number of minutes (5–120) before a zone test ends and press #.

**Unlock Button Action (Default = 4)** xx057  
**Lock Button Action (Default = 9)** xx058  
**Lights Button Action (Default = 15)** xx059  
**Star Button Action (Default = 12)** xx060  
**Lights/Star Button Combination Action (Default = 3)** xx061  
**Direct Arm Level—3 Action (Default = 6)** xx063  
**Direct Arm Level—2 Action (Default = 5)** xx064  
**Lock/Star Button Combination Action (Default = 16)** xx065  
**Disarm/Lights Button Combination Action (Default = 16)** xx066

These settings allow you to specify how the system behaves when specific keychain touchpad button or button combinations are pressed.

**Special Action Assignments:**

- 0- not used
- 1- not used
- 2- not used
- 3- auxiliary panic (only used for item no. xx061)
- 4- arm to level 1
- 5- arm to level 2
- 6- arm to level 3
- 7- arm to special level 4
- 8- arm to special level 5
- 9- arm to closed level
- 10- arm to closed level with no delay
- 11- arm to closed level with Latchkey
- 12- increment arming level from 0 to 1, 1 to 2, or 2 to 3 only
- 13- turn all\* lights on
- 14- turn all\* lights off
- 15- toggle all\* lights
- 16- do nothing

\* all lights having the first (of two) house codes in the partition.

**Specifying Keychain Touchpad Button Action:**

1. Once the desired item number has been entered, enter the special action assignment number (3–16) from the above list.
2. Press # to apply the new setting.

**Auxiliary Medical Panic Keys** xx086  
Default = 1 (On)

Choose whether or not to enable the Auxiliary panic buttons on touchpads. If enabled, when a user presses and holds the Auxiliary panic buttons or presses them twice, an auxiliary or medical alarm is generated. See *Auxiliary/Medical Assignment setting (xx084)*.

**To Turn This Setting On/Off:**

Once the item number has been entered, enter 1 to turn the setting on (enabled) or 0 to turn it off. Press # to apply the new setting.

**Enable Police Panic Keys** xx085  
Default = 1 (On)

Choose whether or not to enable the Police panic buttons on touchpads. If enabled, when a user presses and holds the police panic buttons or presses them twice, a police alarm is generated.

**To Turn This Setting On/Off:**

Once the item number has been entered, enter 1 to turn the setting on (enabled) or 0 to turn it off. Press # to apply the new setting.

**Enable Fire Panic Keys** xx087  
Default = 1 (On)

Choose whether or not to enable the Fire panic buttons on touchpads. If enabled, when a user presses and holds the fire panic buttons or presses them twice, a fire alarm is generated.

**To Turn This Setting On/Off:**

Once the item number has been entered, enter 1 to turn the setting on (enabled) or 0 to turn it off. Press # to apply the new setting.

**Auxiliary/Medical Assignment** xx084  
Default = 1 (On—Auxiliary Alarm)

Choose whether the Auxiliary/Medical panic buttons are used to produce an auxiliary (on) or medical (off) alarm.

**Note**

In order for an auxiliary or medical alarm to be produced by the pressing of the panic buttons, they must be enabled. See the Auxiliary Medical Panic Enable setting xx086.

**Selecting the Alarm Type:**

Once the item number has been entered, enter 1 to turn the setting on (auxiliary) or 0 to turn it off (medical). Press # to apply the new setting.

**Codes**

The settings below cover only installer programming codes. For information on user access code programming, please refer to the *User's Guide*.

Dealer Access Code Default = None	17107
Enter a six-digit Dealer Access code. This code is used to access special programming menus such as setting reporting phone numbers or account numbers when the panel is in program mode. If this code is not set, these programming menus require no special code to access.	
<b>Setting the Dealer Access Code:</b>	
<ol style="list-style-type: none"> <li>Once the item number has been entered, enter any six-digits (0–9) then press #.</li> <li>When prompted, enter the six-digit code again (for verification), and press #.</li> <li>The touchpad will display NEW CODE OK.</li> </ol>	
<b>Changing/Deleting the Dealer Access Code:</b>	
<ol style="list-style-type: none"> <li>Once the item number has been entered, enter the six-digit dealer code.</li> <li>Wait until the touchpad displays ENTER NEW CODE then <ul style="list-style-type: none"> <li><input type="checkbox"/> enter a new six-digit dealer code or,</li> <li><input type="checkbox"/> enter 0 + # to delete the dealer access code (no code).</li> </ul> </li> <li>Enter the new code again.</li> <li>The touchpad will display NEW CODE OK.</li> </ol>	
<p><b>Note</b> If a Dealer Access Code has been set clearing the panel's memory will <u>not</u> clear the Dealer Access Code, Reporting Phone Numbers, or Account Numbers. If the Dealer Access Code is set, the forgotten, the only way to clear it is to return the panel to the factory.</p>	

Downloader Access Code Default = 12345	17108
Enter a five-digit access code to be used in conjunction with downloader programming.	
<p><b>Note</b> This code must match (or be left at default) the downloader access code programmed in downloader in order for the two to communicate.</p>	
<b>Changing the Downloader Access Code:</b>	
<ol style="list-style-type: none"> <li>Enter the item number.</li> </ol> <p><b>Note</b> If a Dealer Access Code has been programmed, you will be prompted to enter it.</p> <ol style="list-style-type: none"> <li>Once the Dealer Access Code has been entered (if applicable) the touchpad will display the current Downloader Access Code.</li> <li>Enter any five-digits (0–9) for the new Downloader Access code, then press #.</li> </ol>	

Access Code Length Default = 4	50013
Select the required length of <i>all</i> installer, primary, and user access codes. If the access code length is changed, then all access codes will automatically be updated to the correct length. Access codes that contained less digits than the new length will be given leading zeros (1234 = 001234). Access codes that contained more digits than the new length will be have the first digit(s) removed (987654 = 7654).	
<b>Changing the Access Code Length:</b>	
<ol style="list-style-type: none"> <li>Enter the item number. The current code length will be displayed.</li> <li>Enter the new code length (4–6) and press #.</li> </ol>	

## Phone Settings

Enable Phone Line 1 DTMF Dialing	17094
Enable Phone Line 2 DTMF Dialing	17095
Defaults = 1 (On)	
Select whether or not you want to enable the phone line for DTMF (touch-tone) dialing. If off, the panel will dial using pulse format.	
<b>To Set Dialing format:</b>	
Once the item number has been entered, enter 1 to turn this setting on (DTMF dialing) or 0 to turn it off (pulse dialing). Press # to apply the new setting.	

Phone Line 1 Dialing Prefix	17105
Phone Line 2 Dialing Prefix	17106
Defaults = None	
Enter up to a six-digit phone line dialing prefix. Use this setting to access an outside line, disable call waiting, etc.	
<b>Line Dial Prefix Format</b>	
<input type="checkbox"/> Enter 00–09 for numbers 0-9 <input type="checkbox"/> Enter 10 for * (star) <input type="checkbox"/> Enter 11 for # (pound) <input type="checkbox"/> Enter 12 for D (1–5 second delay) <input type="checkbox"/> Enter 13 for W (wait for dial tone)	
<b>Setting a Line Dialing Prefix:</b>	
<ol style="list-style-type: none"> <li>Once the desired item number has been entered the current line dial prefix will be displayed.</li> <li>Enter up to a six-digit phone line dialing prefix using the format above and press #.</li> </ol>	
<b>Deleting a Line Dialing Prefix:</b>	
<ol style="list-style-type: none"> <li>Once the desired item number has been entered the current line dial prefix will be displayed.</li> <li>Enter 0 + #. The touchpad will display NO DATA.</li> </ol>	

<b>Buddy Dial Attempts</b> Default = 5	17101
Set the number of dialing attempts (to central station) before a buddy transmission is generated.	
<b>Setting the Number of Buddy Dial Attempts:</b>	
Once the item number has been entered, enter the number of buddy dial attempts (0-11)* and press #.	
* 0 = immediate transmit request, 11 = no transmit request.	

<b>No Phone Line</b> Default = 0 (Off)	17069
Turn this setting on if there is no phone line connected to the panel. When on, the panel will not check for phone line failure.	
<b>Turning No Phone Line Setting On/Off:</b>	
Once the item number has been entered, enter 1 to turn this setting on (no phone line) or 0 to turn it off (phone line). Press # to apply the new setting.	

<b>System Account Number 1</b>	17102	
<b>System Account Number 2</b>	17103	
Defaults = 00000000		
Enter an 8-digit system account number which will identify the panel to the central station when reporting system events. System Account Number 1 is reported on reporting phone 1 and its backup. System account number 2 is reported on reporting phone 2 and its backup.		
Account Number Format:		
☐ for 0 enter 00	☐ for 6 enter 06	☐ for C enter 12
☐ for 1 enter 01	☐ for 7 enter 07	☐ for D enter 13
☐ for 2 enter 02	☐ for 8 enter 08	☐ for E enter 14
☐ for 3 enter 03	☐ for 9 enter 09	☐ for F enter 15
☐ for 4 enter 04	☐ for A enter 10	
☐ for 5 enter 05	☐ for B enter 11	
<b>To Enter a System Account Number</b>		
1. Once the desired item number has been entered the current system account number will be displayed.		
<b>Note</b> If a Dealer Access Code has been programmed, you will be prompted to enter it.		
2. Enter the new system account number using the list above. For example, if you wanted the system account number to be "123456AB," at the keypad you would enter "01, 02, 03, 04, 05, 06, 10, 11."		
3. Press # and the touchpad displays the new system account number.		
<b>Note</b> System account numbers must equal 8 characters. If you enter less than 8 characters the panel will automatically replace the blank spaces with leading zeros (0).		

<b>Pager ID</b> Default = 00000	17058
The Pager ID identifies the panel to pager-holders. Select the ID to be sent with pager reports.	
<b>Setting System Pager ID:</b>	
Once the item number has been entered, enter the 5-digit Pager ID (00000-99999) to be sent with pager reports and press #.	

<b>Interval Between Automatic Phone Test</b>	17034
Default = 1 (Commercial), 7 (Home Navigator)	
Select the number of days between automatic phone test reports to all enabled central station phone numbers. Entering 0 will disable automatic phone test.	
<b>To Set Automatic Phone Test Interval:</b>	
Once the item number has been entered (17-034), enter THE NUMBER OF DAYS (0-255). Press # to apply the new setting.	

### Specific Phone Number Settings

Specific phone number settings allow you to program central monitoring station, downloader, and pager phone numbers.

#### Note

If a Dealer Access Code has been programmed, you will be prompted to enter it when setting/changing specific phone settings.

- ☐ Phone numbers 19–22 are central monitoring station reporting phone numbers and function as follows:  
19 = phone 1  
20 = phone 1 backup  
21 = phone 2  
22 = phone 2 backup
- ☐ Phone numbers 23–24 are downloader phone numbers and function as follows:  
23 = phone 3  
24 = phone 3 backup
- ☐ Phone numbers 25–40 are reporting pager phone numbers 1 through 16.

### Central Monitoring Station and Downloader Phone Number Settings

<b>Phone Number Enable</b> Default = 0 (Off)	yy001
Select whether or not to enable the phone number. If on, the panel will use the number when reporting or downloading. If off, the number will be skipped.	
<b>To Turn Reporting Phone Number On/Off:</b>	
Once the item number has been entered (19001–24001), enter 1 to turn this setting on (call), or 0 to turn it off (no call). Press # to apply the new setting.	

<b>Phone Number</b> Default = None	<b>yy002</b>
<p>Enter up to a 24-digit phone number for reporting or downloading.</p> <p>Phone Number Format</p> <ul style="list-style-type: none"> <li><input type="checkbox"/> Enter 00–09 for numbers 0-9</li> <li><input type="checkbox"/> Enter 10 for * (star)</li> <li><input type="checkbox"/> Enter 11 for # (pound)</li> <li><input type="checkbox"/> Enter 12 for D (1–5 second delay)</li> <li><input type="checkbox"/> Enter 13 for W (wait for dial tone)</li> </ul> <p><b>To Enter a Phone Number:</b></p> <ol style="list-style-type: none"> <li>Enter the desired item number (ex. 19002).</li> <li>Enter the phone number using the list above. For example, if you wanted the phone number to be “1235551212,” at the keypad you would enter “01, 02, 03, 05, 05, 05, 01, 02, 01, 02.”</li> <li>Press # and the touchpad displays the new phone number.</li> </ol> <p><b>Note</b> In order for the phone number to be used for reporting events or downloading, it must be enabled. See the Phone Number Enable setting (yy001).</p> <p><b>To Delete a Phone Number:</b></p> <ol style="list-style-type: none"> <li>Enter the desired item number.</li> <li>Enter 0 + #. The touchpad will display NO DATA.</li> </ol>	

<b>Number of Attempts</b> Default = 5	<b>yy003</b>
<p>Set the number of times (attempts) the panel will dial (and report) to the reporting or downloader phone number.</p> <p><b>Note</b> 19003 for phones 1 and its backup, 21003 for phones 2 and its backup.</p> <p><b>Setting the Number of Dial Attempts:</b></p> <p>Once the item number has been entered, enter the number of dial attempts (5–10) and press #.</p>	

<b>Communication Format</b> Default = 0 (Contact ID)	<b>yy004</b>
<p>Select the type of communication format the panel will use when reporting events to the central station.</p> <p><b>Note</b> Currently only Contact ID format is supported.</p>	

<b>Report Panic Special</b> Default = 0 (Off)	<b>yy005</b>
<p>Choose how the panel formats touchpad panic alarm reports to the central station. When on, touchpad panic alarms report using the following special 3-digit codes:</p> <ul style="list-style-type: none"> <li><input type="checkbox"/> Fire Panic—599</li> <li><input type="checkbox"/> Police Panic—598</li> <li><input type="checkbox"/> Auxiliary Panic—597</li> <li><input type="checkbox"/> Medical Panic—596</li> </ul> <p>When off, panics will report as “500” plus the bus device number. For example, a keypad with bus device number “03” would report as “503.”</p> <p><b>Turning Report Panic Special On/Off:</b></p> <p>Once the item number has been entered, enter 1 to turn this setting on (report panic special), or 0 to turn it off (not special). Press # to apply the new setting.</p>	

**Pager Phone Number Settings**

<b>Pager Phone Number Enable</b> Default = 0 (Off)	<b>zz001</b>
<p>Select whether or not to enable the pager phone number. If on, number will report events to the pager. If off, the number will be skipped when the panel is reporting to pagers.</p> <p><b>To Turn Reporting Pager Phone Number On/Off:</b></p> <ol style="list-style-type: none"> <li>Once the item number has been entered (25001–40001), enter 1 to turn this setting on (page), or 0 to turn it off (no page).</li> <li>Press # to apply the new setting.</li> </ol>	

<b>Pager Phone Number</b> Default = None	<b>zz002</b>
<p>Enter up to a 24-digit phone number for pager reporting.</p> <p>Pager Phone Number Format</p> <ul style="list-style-type: none"> <li><input type="checkbox"/> Enter 00–09 for numbers 0-9</li> <li><input type="checkbox"/> Enter 10 for * (star)</li> <li><input type="checkbox"/> Enter 11 for # (pound)</li> <li><input type="checkbox"/> Enter 12 for D (1–5 second delay)</li> <li><input type="checkbox"/> Enter 13 for W (wait for dial tone)</li> </ul> <p><b>To Enter a Pager Phone Number:</b></p> <ol style="list-style-type: none"> <li>Enter the desired item number (ex. 25002).</li> <li>Enter the phone number using the list above. For example, if you wanted the pager phone number to be “1235551212,” at the keypad you would enter “01, 02, 03, 05, 05, 05, 01, 02, 01, 02.”</li> <li>Press # and the touchpad displays the new pager phone number.</li> </ol> <p><b>Note</b> In order for the panel to report events to the pager the pager phone number must be enabled. See Pager Phone Number Enable setting (zz001).</p> <p><b>To Delete a Pager Phone Number:</b></p> <ol style="list-style-type: none"> <li>Enter the desired item number.</li> <li>Enter 0 + #. The touchpad will display NO DATA.</li> </ol>	

<b>Number of Attempts</b> Default = 3	zz003
Set the number of times (attempts) the panel will try to dial the pager phone number.	
<b>Setting the Number of Dial Attempts:</b>	
Once the item number has been entered, enter the number of dial attempts (3–10) and press #.	

<b>Communication Format</b> Default = 1 (TAP at 1200 bps PSK)	zz004
Select the type of communication format the panel will use when reporting events to pagers. Consult your paging service provider for help in setting this option.	
Communication Formats:	
<input type="checkbox"/> Enter 0 for TAP at 300 bps (FSK).	
<input type="checkbox"/> Enter 1 for TAP at 1200 bps (PSK).	
<b>Setting the Communication Format</b>	
1. Once the item number has been entered, use the choices above to select a communication format.	
2. Press # to apply the new setting.	

<b>Communication Character Format</b> Default = 1 (7/E/1)	zz005
Select the character format the panel will use when reporting to pagers. Consult your paging service provider for help in setting this option.	
Character Formats	
<input type="checkbox"/> Enter 0 for 8/N/1.	
<input type="checkbox"/> Enter 1 for 7/E/1.	
<b>Setting the Character Format</b>	
1. Once the item number has been entered, press 0 for 8/N/1 character format (off), or 1 for 7/N/1 character format (on).	
2. Press # to apply the setting.	

<b>Pager System Reports</b> Default = 0 (Off)	zz006
Select whether or not you want system events reported to pager.	
<b>To Turn System Pager Report On/Off:</b>	
Once the item number has been entered, enter 1 to turn this setting on (report), or 0 to turn it off (don't report). Press # to apply the new setting.	

<b>Partition/Area 1 Reports</b> (Defaults = 0, Phone 25 = 1)	zz007
<b>Partition/Area 2 Reports</b> (Defaults = 0, Phone 26 = 1)	zz008
<b>Partition/Area 3 Reports</b> (Defaults = 0, Phone 27 = 1)	zz009
<b>Partition/Area 4 Reports</b> (Defaults = 0, Phone 28 = 1)	zz010
<b>Partition/Area 5 Reports</b> (Defaults = 0, Phone 29 = 1)	zz011*
<b>Partition/Area 6 Reports</b> (Defaults = 0, Phone 30 = 1)	zz012*
<b>Partition/Area 7 Reports</b> (Defaults = 0, Phone 31 = 1)	zz013*
<b>Partition/Area 8 Reports</b> (Defaults = 0, Phone 32 = 1)	zz014*
Select whether or not you want partition/area events to report to pager(s).	
<b>To turn Partition/Area Report On/Off:</b>	
1. Once the item number has been entered, enter 1 to turn this setting on (report), or 0 to turn it off (don't report).	
2. Press # to apply the new setting.	
* This option setting is available on 8 partition panel types only (60-562-01 and 60-562-05).	

<b>Pager PIN</b> Default = None	zz015
Enter up to a 15-digit pager PIN. Consult your paging service provider for help in setting this option.	
<b>To Enter a Pager PIN:</b>	
1. Enter the desired item number (ex. 25015).	
2. Enter up to a 15-digit (0–9) pager PIN.	
3. Press # and the touchpad displays the pager PIN.	

<b>Pager Message Length</b> Default = 120 Characters	zz016
Set the maximum character length for pager messages. Consult your paging service provider for help in setting this option.	
<b>Setting Maximum Pager Message Length:</b>	
Once the item number has been entered, enter the maximum pager length (0–255) and press #.	

### Advanced Phone Settings



#### CAUTION

Only qualified persons should make changes to advanced phone settings.

<b>Maximum Ring Cycle Time</b> Default = 67 Milliseconds	17018
Specify (in milliseconds) the maximum cycle time for the ring signal.	
<b>Setting the Maximum Ring Cycle Time:</b>	
1. Once the item number has been entered, specify the maximum ring cycle time (0–255).	
2. Press # to apply the new setting.	

**Minimum Tone Duration** 17031  
**Default = 3 (30 ms)**

Specify the minimum duration of a valid DTMF (touch-tone) tone in 10 millisecond increments (1–100 x 10 ms). This is the minimum amount of time that a phone number button must be pressed in order to be valid.

**Setting the Minimum Tone Duration:**

1. Once the item number has been entered, specify the minimum tone duration (1–100).
2. Press # to apply the new setting.

**Minimum Duration Between Tones** 17032  
**Default = 5 (50 ms)**

Specify the minimum duration of pause between DTMF (touch-tone) tones in 10 millisecond increments (1–100 x 10 ms). This is the minimum amount of time required between two phone number buttons being pressed.

**Setting the Minimum Duration Between Tones:**

1. Once the item number has been entered, specify the minimum duration between tones (1–100).
2. Press # to apply the new setting.

**Minimum Valid Ring Cycles** 17054  
**Default = 2 Cycles**

Specify the minimum number of cycles in a valid ring.

**Setting the Minimum Valid Ring Cycles:**

1. Once the item number has been entered, specify the minimum number of cycles (0–255).
2. Press # to apply the new setting.

**Valid Ring Bursts** 17055  
**Default = 1 Burst**

Specify the number of ring bursts in a valid ring.

**Setting the Number of Ring Bursts:**

1. Once the item number has been entered, specify the number of ring bursts (1–5).
2. Press # to apply the new setting.

**Valid Ring at Beginning or End of Ring Burst** 17091  
**Default = 0 (Off)**

Selects if a ring is considered valid at the beginning of the ring burst or at the end of the ring burst.

**Setting Valid Ring at Beginning or End of Cycle:**

Once the item number has been entered, enter 1 or 0. Press # to apply the new setting.

**Maximum Ring Burst Duration** 17020  
**Default = 250 (2500 ms)**

Specify the maximum duration of a valid ring burst in 10 ms increments (3–300 x 10 ms).

**Setting the Maximum Ring Burst Duration:**

1. Once the item number has been entered, specify the maximum ring burst duration (3–300).
2. Press # to apply the new setting.

**Minimum Ring Burst Duration** 17019  
**Default = 40 (400 ms)**

Specify the minimum duration of a valid ring burst in 10 ms increments (3–300 x 10 ms).

**Setting the Minimum Ring Burst Duration:**

1. Once the item number has been entered, specify the minimum ring burst duration (3–300).
2. Press # to apply the new setting.

**Maximum Duration Between Ring Bursts** 17022  
**Default = 0**

Specify the maximum duration between valid ring bursts in 10 millisecond increments (0–300 x 10 ms).

**Setting the Maximum Duration Between Ring Bursts:**

1. Once the item number has been entered, specify the maximum duration between ring bursts (0–300).
2. Press # to apply the new setting.

**Minimum Duration Between Ring Bursts** 17021  
**Default = 0**

Specify the minimum duration between valid ring bursts in 10 millisecond increments (0–300 x 10 ms).

**Setting the Minimum Duration Between Ring Bursts:**

1. Once the item number has been entered, specify the minimum duration between ring bursts (0–300).
2. Press # to apply the new setting.

**Maximum Time Between Rings** 17024  
**Default = 450 (4500 ms)**

Specify the maximum amount of time allowed between valid rings in 10 millisecond increments (100–999 x 10 ms).

**Setting the Maximum Time Between Rings:**

1. Once the item number has been entered, specify the maximum time between rings (100–999).
2. Press # to apply the new setting.

**Minimum Time Between Rings** 17023  
 Default = 200 (2000 ms)

Specify the minimum amount of time allowed between valid rings in 10 millisecond increments (100–999 x 10 ms).

**Setting the Minimum Time Between Rings:**

1. Once the item number has been entered, specify the minimum time between rings (100–999).
2. Press # to apply the new setting.

**Phone Access Settings**
**Local Phone Settings**

Local phone settings allow you to choose how phones located on the same premises as the panel interact with the system.

**Enable Local Phone Access in Partition/Area 1** 17085  
 Default = 0 (Off - Commercial Burg)  
 Default = 1 (On - Home Navigator)

This setting allows you to enable local phone control in partition/area 1. If on, partition/area 1 may be controlled by local on-premises phones.

**To Turn Local Phone Access in Partition/Area 1 On/Off:**

Once the item number has been entered, enter 1 to turn this setting on, or 0 to turn it off. Press # to apply the new setting.

**Local Phone Control Sequence** 17056  
 Default = #\*

Enter up to a 4-digit DTMF (touch-tone) sequence for local phone control. This is the sequence of numbers the user will have to enter when accessing the panel locally (on-site). Partition/area 1 only.

Format:

- Enter 00–09 for numbers 0-9.
- Enter 10 for \* (star).
- Enter 11 for # (pound).

**To Enter Local Phone Control Sequence:**

1. Enter the item number.
2. Enter the sequence using the format above. For example, if you wanted the sequence to be "12#\*," at the keypad you would enter "01, 02, 11, 10."
3. Press # and the touchpad displays the new sequence.

**To Delete the Local Phone Control Sequence:**

1. Enter the item number.
2. Enter 0 + #. The touchpad will display NO DATA.

**Phone Device Override Sequence** 17057  
 Default = \*\*##

Enter up to a 4-digit DTMF (touch-tone) sequence for phone device override. This sequence will instruct the panel to seize the line from the local phone and initiate a remote connection. Users will be able to enter this sequence and bypass any phone devices (answering machines, fax machines, etc.) when calling from a remote phone. Partition/area 1 only.

Format:

- Enter 00–09 for numbers 0-9.
- Enter 10 for \* (star).
- Enter 11 for # (pound).

**To Enter Phone Device Override Sequence:**

1. Enter the item number.
2. Enter the sequence using the format above. For example, if you wanted the sequence to be "12#\*," at the keypad you would enter "01, 02, 11, 10."
3. Press # and the touchpad displays the new sequence.

**To Delete Phone Device Override Sequence:**

1. Enter the item number.
2. Enter 0 + #. The touchpad will display NO DATA.

**Time Between Phone Panic Keystrokes** 17030  
 Default = 2 Seconds

Specify the maximum time allowed (in seconds) between keystrokes in a phone panic sequence. If this delay is exceeded, a panic alarm will not be activated. Partition/area 1 only.

**Setting the Time Between Phone Panic Keystrokes:**

1. Once the item number has been entered, enter the maximum delay (1–5).
2. Press # to apply the new setting.

**Local Phone Connect Time** 17028  
 Default = 5 Seconds

Specify the maximum time allowed (in seconds) between local phone off-hook and DTMF seize sequence for local phone control. If the maximum time is exceeded, remote phone control will be put on hold. Partition/area 1 only.

**Setting the Local Phone Connect Time:**

1. Once the item number has been entered, enter the maximum allowable connect time (0–255 [0 = no max time]).
2. Press # to apply the new setting.

**Local Phone Answer Time** 17029  
 Default = 8 Seconds

Specify the maximum time (in seconds) between a ring signal and local phone off-hook signal to be considered answer of call. Partition/area 1 only.

**Setting the Local Phone Answer Time:**

1. Once the item number has been entered, enter the answer time (0–255).
2. Press # to apply the new setting.

**On Hook Hang Up Time** 17027  
**Default = 4 Seconds**

Select the amount of time (in seconds) a local telephone must be on-hook before hanging up. Partition/area 1 only.

**Setting the On Hook Hang Up Time:**

1. Once the item number has been entered, enter the hang up time (2–10).
2. Press # to apply the new setting.

**Phone Police Panic Enable** 17080  
**Phone Aux/Med Panic Enable** 17081  
**Phone Fire Panic Enable** 17082  
**Defaults = 0 (Off)**

Select whether or not you want to enable the selected phone panic sequence. If on, users will be able to activate the specific panic alarm using a local phone (88888 for police, 77777 for auxiliary/medical, and 99999 for fire). Partition/area 1 only.

**To Turn Phone Panic On/Off:**

Once the desired item number has been entered, enter 1 to turn this setting on, or 0 to turn it off. Press # to apply the new setting.

**Remote Phone Settings**

Remote phone settings allow you to choose how phones located off premises (different line) interact with the panel.

**Enable Remote Phone Access** 17086  
**Default = 1 (On)**

**Note**  
 Turning this setting to “off” will prevent the panel from receiving future downloader calls.

This setting allows you to enable remote phone access. If on, the panel may be controlled using remote off-site phones. Partition/area 1 only.

**Note**  
 For residential use only.

**To Turn Remote Phone Access On/Off:**

1. Once the item number has been entered, enter 1 to turn this setting on (enabled), or 0 to turn it off.
2. Press # to apply the new setting.

**Enable Remote Phone Ring Count** 17087  
**Default = 1 (On)**

This setting allows you to tell the panel to count remote phone rings so that it will pick up after a certain number of rings. This setting only works if *Remote Phone Access* setting (above) is set to “on”. Partition/area 1 only.

For residential use only.

**To Turn Remote Phone Ring Count On/Off:**

1. Once the item number has been entered, enter 1 to turn this setting on, or 0 to turn it off.
2. Press # to apply the new setting.

**Answer Phone after XX Rings** 17052  
**Default = 12 Rings**

Specify the number of rings after which the panel will answer an incoming phone call. The *Remote Phone Ring Count* (17087) setting must be set to “on” for this setting to work. Partition/area 1 only.

**Note**  
 For residential use only.

**To Set the Number of Rings:**

1. Once the item number has been entered, specify the maximum number of rings (1–12).
2. Press # to apply the new setting.

**Enable Toll Saver** 17090  
**Default = 1 (On)**

Choose whether or not to enable the panel to answer a remote phone up to 4-rings earlier than normal if an alarm condition or system trouble has occurred. Normal is considered the value in *Answer Phone After XX Rings* setting (17052). The *Remote Phone Ring Count* setting (17087) must be set to “on” for this setting to take effect. Partition/area 1 only.

**Note**  
 For residential use only.

**To Turn Toll Saver On/Off:**

1. Once the item number has been entered, enter 1 to turn this setting on, or 0 to turn it off.
2. Press # to apply the new setting.

**Enable Remote Phone Ring-Pause-Ring** 17088  
**Default = 1 (On)**

This setting allows you to program the panel to answer remote phone ring-pause-rings. When on, a user can call the panel once, hang up, and call again. The panel will then answer the phone. Use this setting if an answering machine shares a phone line with the panel. Partition/area 1 only.

**Note**  
 The user must not exceed the number of rings in the *Cancel Ring Pause Ring after XX Rings* setting (17053) when calling the panel. Additionally, the user must call the panel again between the times programmed in settings 17025 and 17026.

For residential use only.

**To Turn Remote Phone Ring-Pause-Ring On/Off:**

Once the item number has been entered, enter 1 to turn this setting on, or 0 to turn it off. Press # to apply the new setting.

**Min Time Between Ring-Pause-Ring Calls** 17025  
**Default = 10 Seconds**

Specify the minimum time (in seconds) between ring-pause-ring calls. This is the minimum amount of time that must elapse before the second call in a ring-pause-ring attempt. Partition/area 1 only.

**Setting the Minimum Time Between Ring-Pause-Ring Calls:**

1. Once the item number has been entered, specify the minimum time (6–20).
2. Press # to apply the new setting.



**Max Time Between Ring-Pause-Ring Calls** 17026  
 Default = 30 Seconds

Specify the maximum time (in seconds) between ring-pause-ring calls. This is the maximum amount of time that may elapse before the second call in a ring-pause-ring attempt. If this time is exceeded, the current ring-pause-ring attempt will be canceled. Partition/area 1 only.

**Setting the Maximum Time Between Ring-Pause-Ring Calls:**

1. Once the item number has been entered, specify the maximum time (7–60).
2. Press # to apply the new setting.

**Cancel Ring Pause Ring After XX Rings** 17053  
 Default = 3 Rings

Specify the number or rings at which ring-pause-ring is aborted. For example, if this setting is set at 3, then (during the first call) at 3 rings, ring-pause-ring will be aborted. Partition/area 1 only.

**Setting Cancel Ring Pause Ring After XX Rings:**

1. Once the item number has been entered, specify the maximum number of rings (2–10).
2. Press # to apply the new setting.

**Enable Remote Phone Override** 17089  
 Default = 1 (On)

If on, users may cut off a local phone call or answering machine to access the panel from a remote phone. Partition/area 1 only.

**Note**  
For residential use only.

**To Turn Remote Phone Override On/Off:**

1. Once the item number has been entered, enter 1 to turn this setting on, or 0 to turn it off.
2. Press # to apply the new setting.

**Allow Remote Phone Zone Test** 17098  
 Default = 1 (On)

If on, users may perform zone tests from remote phones. Partition/area 1 only.

**To Turn Remote Phone Zone Test On/Off:**

1. Once the item number has been entered, enter 1 to turn this setting on, or 0 to turn it off.
2. Press # to apply the new setting.

## Zone Settings

Use zone settings to add, delete, test, and modify zones.

**Note**  
It is recommended that no more than 132 wireless sensors be used in any individual Advent system.

If 2 or more Advent systems are in close proximity to each other, the total number of wireless sensors for *all* systems must not exceed 132.

**Add (Learn) Zones** 47001  
 Default = NA

Use this item number to add (learn) hardwire zones and wireless devices into panel memory.

**To Learn Zones Into Panel Memory:**

1. Once in program mode enter item number 47001. The display shows ENTER PARTITION/AREA NUMBER OR PRESS \* TO CANCEL.
2. Enter the desired one-digit partition/area number (1–8) and press #. The display shows ENTER ZONE TYPE OR PRESS \* TO CANCEL.

**Note**

If the partition/area is not enabled, the display will show PARTITION/AREA nn INVALID. See item number xx068 to enable partition/area(s).

3. Enter the two-digit zone type number (00–96) and press #. Refer to “Table B1 in Appendix B” on page 80 for zone type descriptions.

If zone type 84 (Enhanced Buddy) is selected the zone number prompt is skipped and buddy learn mode is automatically entered. While in this mode, the panel sends and receives buddy learn messages and adds (learns) all buddies that it detects (up to 4) when the \* or # button is pressed in this mode, the panel automatically proceeds to buddy test mode where a buddy test message is sent and acknowledged by all buddy panels. At the end of this test, the panel indicates the IDs of the buddy panels, and the received signal strength from each.

4. The display shows LEARN ZONE nn ENTER NEW ZONE NUMBER OR PRESS # TO ACCEPT, where *nn* is the next available zone number. If desired, enter a different zone number. Press #.
5. When the display shows TRIP ZONE n, use the guidelines below and on this page to trip the zone you are adding which learns it into panel memory.
6. The display shows ZONE nn TYPE nn PARTITION/AREA n OK.
7. To add another zone to the same zone type and partition/area, go to step 5.

To add zones to another zone type (same partition/area) press # and go back to step 3.

To add zones to another zone type and partition/area press \* and repeat the above procedure (exits to programming).

**Note**

Make sure wireless touchpads that may be removed from the premises such as portable and keychain touchpads are assigned to an *unsupervised* zone type such as 87. Assign permanently mounted wireless touchpads to supervised zone type 86.

## Tripping Hardwire Zones

- ❑ **Hardwire Zones**—Start with the zone in its “normal” state, then trip the zone into its alarm state. A normally closed door, for example, should be closed when you begin the Add Zones process. Trip the zone by opening the door.
- ❑ On hardwired zones containing multiple sensors, only one needs to be tripped for the panel to learn the zone.
- ❑ The alarm state is either open or closed, depending on the normal condition of the sensor. Multiple normally closed switches are wired in series and tripped open. Multiple normally open switches are wired in parallel and tripped closed.

### Tripping Learn Mode Wireless Sensors\*

To trip a wireless sensor with an external hardwired contact connected to its screw terminals, check that the external contact is in its alarm state, then activate the sensor tamper.

For high-security installations, always remove both internal reed switches when connecting an external contact to the wireless sensor terminals.

Only the normally closed configuration can be used in UL- listed installations.

Do not attempt to use the built-in magnetic reed switch *and* an external contact on the same wireless sensor.

On hardwired sensors connected to the external contacts of a wireless transmitter, the alarm state is either open or closed, depending on the normal condition of the sensor. Multiple normally closed switches are wired in series and tripped while the loop is open. Multiple normally open switches are wired in parallel and tripped while the loop is closed.

- Door/Window Sensors with External Contacts**—Place the external contact in the alarm condition, then activate the sensor tamper switch (remove cover).
- Fire Pull Station**—Actuate the sensor. Open the sensor cover located inside the fire pull station.
- Glass Guard**—Open sensor cover.
- Portable Emergency Buttons**—Press and hold emergency button(s).
- PIR Motion**—Open PIR case.
- Rate-of Rise-Heat**—Open sensor cover and press learn switch on circuit board.
- Recessed Door/Window**—Open sensor cover and remove transmitter circuit board.
- Micro Recessed Door/Window**—Short contacts in small screwdriver slot.
- Shock Sensor\*\***—Open sensor cover.
- Slim Line Door/Window**—Remove sensor from mounting base.
- ITI Sound**—Open sound sensor cover after spring is installed.
- Smoke (System Sensor 2100RF)**—Remove base.
- Smoke (System Sensor 2100ARFT)**—Remove base.
- Smoke (Sentrol 560)**—Remove base.
- Smoke (Sentrol 570)**—Remove base.
- Pressure Switch Sensor**—Hold a magnet next to the sensor cover where indicated (does not require cover removal).
- 2 and 4 Button Keychain Touchpads**—Simultaneously press Lock and Unlock buttons until the touch-

\* Refer to the specific sensor/touchpad Installation Instructions for more details on tripping sensors/touchpads.

\*\* When using an external contact with this sensor, the contact must be in the alarm state while tripping the sensor to properly learn it into memory.

pad LED flashes (added [learned] in a sensor zone type).

- Handheld**—Press Bypass button.
- HiTech Wall-Mount**—Press Bypass button.
- HiTech Handheld**—Press Bypass button.

Delete Zones Default = NA	47002
Use this item number to delete zones from panel memory. You must delete zones one at a time.	
<p><b>Note</b> Deleting zones does not delete the zone text associated with the deleted zone number. To delete zone text use item number 49001.</p>	
<p><b>To Delete Zones from panel memory:</b></p> <ol style="list-style-type: none"> <li>Once in program mode enter 47002. The display shows ENTER ZONE NUMBER OR PRESS * TO CANCEL.</li> <li>Enter the 3-digit zone number you wish to delete and press #.</li> <li>The display shows ZONE nn DELETED.</li> <li>To delete another zone, repeat the above procedure.</li> </ol>	

Zone Text Default = None	49001
Use the following guidelines to “name” zones.	
<ul style="list-style-type: none"> <li><input type="checkbox"/> Use the item numbers that appear in Table B2 on page 85 for characters and words listed there.</li> <li><input type="checkbox"/> If a desired word does not appear in Table B2, create it using the characters (custom text).</li> <li><input type="checkbox"/> When using words from Table B2, spaces between them appear automatically. When using characters from Table B2 to create words, you must reserve an item number for a ‘space’ after the word.</li> <li><input type="checkbox"/> Each character or word uses up one item number. For example, a word from the list counts as one item number. A created word (such as BOY’S) counts as six item numbers—4 letters, 1 apostrophe, and 1 space.</li> <li><input type="checkbox"/> Only 8 item numbers are allowed for each zone name, so plan ahead before programming zone text. You may need to abbreviate words to avoid running out of item numbers.</li> </ul>	
<p><b>To Program Zone Text:</b></p> <ol style="list-style-type: none"> <li>Once in program mode enter 49001. The display shows ENTER ZONE NUMBER OR PRESS * TO CANCEL.</li> <li>Enter the desired zone number and press #. The display shows TEXT FOR ZONE n IS CURRENT ZONE TEXT. ENTER TEXT NUMBERS OR PRESS # TO ACCEPT.</li> <li>Enter the numbers of the desired characters or words. If you make a mistake press * to start over.</li> <li>Press # to accept. The display shows the new zone text.</li> </ol>	
<p><b>To Delete Zone Text:</b></p> <ol style="list-style-type: none"> <li>Once in program mode enter 49001. The display shows ENTER ZONE NUMBER OR PRESS * TO CANCEL.</li> <li>Enter the desired zone number and press #. The display shows TEXT FOR ZONE n IS CURRENT ZONE TEXT. ENTER TEXT NUMBERS OR PRESS # TO ACCEPT.</li> <li>Enter 000 and press #. The display shows TEXT FOR ZONE n IS NO TEXT.</li> </ol>	

### List Zones 47003 Default = NA

Use this item number to list information about existing zones. The system will list the zone number, any zone text, zone type number, and the partition/area number.

#### To List Zones:

Once in program mode enter 47003. The display will show ZONE nn, ANY ZONE TEXT, TYPE nn, PARTITION/AREA n.

The panel will scroll through and display information about each zone. To skip forward press #. To exit press \*. Once the panel lists all the zones it will return to the program menu.

### Zone Attributes (Edit Zones) 47004 Defaults = NA

Use this item number to edit the following zone attributes.

- 1—Critical Security Zone (Default = 0 [Off])  
Enter 0 to turn attribute Off, 1 to turn attribute On. Critical zones require special authority (partition master and full authority codes) in order to be bypassed.
- 2—RF Supervisory Time (Default = A [4 hours - Commercial Burg, 24 hours - Home Navigator])  
Enter 0 for Supervisory Time A (17049), 1 for Supervisory Time B (17050).
- 3—Zone Activity Threshold (Default = 0 [None])  
Enter 0 for None, 1 for Threshold 1 (xx018), 2 for Threshold 2 (xx019), 3 for Threshold 3 (xx020).
- 4—Hardwire Smoke Verify (Default = 0 [Off])  
Enter 0 to turn attribute Off, 1 to turn attribute On. If on, when a hardwire smoke detector is tripped, the panel will remove power for 5 seconds to reset the smoke. If a second trip occurs within 60 seconds, an alarm will sound and a report will be sent to the central station.
- 5—Delayed Zone (Default = 0 Off)  
Enter 0 to turn attribute Off, 1 to turn attribute On. (see 17117).
- 6—Floor (Default = 0 [None])  
Enter the floor number the zone resides on (1–90 above ground, 91–99 below ground, 0 = None) (see 17074).
- 7—not supported.
- 8—not supported.
- 9—not supported.
- 10—Warning message index (Default = 0 [None])  
Enter the desired warning message (1–5). If learned into zone type 70 it will only play the desired warning message.
- 11—Zone Bypass Group (Default = 0 [None])  
Enter the desired bypass group number (0–32). This will allow users to directly bypass and unbypass groups of zones.

#### To Edit Zone Attributes:

1. Once in program mode enter 47004. The display shows ENTER ZONE NUMBER OR PRESS \* TO CANCEL.
2. Enter the desired zone number and press #. The display shows ENTER ATTRIBUTE NUMBER OR PRESS \* TO CANCEL.
3. Enter the attribute number from the list above and press #. The display will show the current attribute setting. If desired, change the attribute setting.
4. Press # to apply changes. To edit another attribute repeat step 1.

### Test Buddies 47005 Default = NA

Use this item number to test zone buddies.

#### To Test Buddies:

Once in program mode enter 47005. The display will show BUDDY TEST MODE. Once the test is complete the display will list buddies (see List Buddies 47006).

### List Buddies 47006 Default = NA

Use this item number to list information about existing buddy zones. The system will list the buddy zone number, ID, and latest buddy test results.

#### To List Buddies:

Once in program mode enter 47006. The display will list all four buddies.

- If the buddy doesn't exist, the panel will display BUDDY n INVALID.
- If the buddy failed the latest test (47005), the panel will display BUDDY n FAILED.
- If the buddy passed the latest test, the signal strength will be displayed.

The panel will scroll through and display information about each buddy. To skip forward press #. To exit press \*. Once the panel lists all the buddies it will return to the program menu.

### Zone Delay Time 17117 Default = 10 Seconds

Set the time delay (in seconds) between a zone being tripped and the trip being processed by the panel. This allows time for a zone to reset.

#### Note

This setting only applies to zones programmed as delayed.

#### To Set Zone Delay Time:

1. Enter the item number.
2. Enter the delay time (1–255 seconds) and press #.

## I/O Settings

Use the following item numbers to specify how inputs and outputs behave.

General Input Response Time 1	17006
General Input Response Time 2	17007
General Input Response Time 3	17008
General Input Response Time 4	17009
General Input Response Time 5	17010
General Input Response Time 6	17011
General Input Response Time 7	17118
Defaults = 32 (0.512 Seconds)	

Each of the seven onboard (snapcard) inputs has a response time. The panel has to “see” a transition for at least that length of time in order to deem it a trip or restoral. At the panel you enter response times in 16 millisecond increments (actual time = value x 16 ms).

### To Program a General Input Response Time:

1. Enter the desired item number.
2. Enter a response time (8–255) and press #.

Expansion Input Response Time 1	17012
Expansion Input Response Time 2	17013
Expansion Input Response Time 3	17014
Expansion Input Response Time 4	17015
Expansion Input Response Time 5	17016
Expansion Input Response Time 6	17017
Expansion Input Response Time 7	17119
Expansion Input Response Time 8	17120
Defaults = 32 (0.512 Seconds)	

Each of the eight expansion inputs has a response time. The panel has to “see” a transition for at least that length of time in order to deem it a trip or restoral. At the panel you enter response times in 16 millisecond increments (actual time = value x 16 ms).

### To Program an Expansion Input Response Time:

1. Enter the desired item number.
2. Enter a response time (8–255) and press #.

General Purpose I/O 1 Direction	17063
General Purpose I/O 2 Direction	17064
General Purpose I/O 3 Direction	17065
General Purpose I/O 4 Direction	17066
General Purpose I/O 5 Direction	17067
General Purpose I/O 6 Direction	17068
Defaults = 0 (Input)	

Select the direction of each general purpose input/output.

### To Program General Purpose Input/Output direction:

1. Enter the desired item number.
2. Enter 1 to set the direction as an output, or 0 to set it as an input. Press # to apply the direction.

Activation Interval One-Shot Time A (Default = 4 Seconds)	17113
Activation Interval One-Shot Time B (Default = 30 Seconds)	17114
Activation Interval One-Shot Time C (Default = 180 Seconds)	17115
Activation Interval One-Shot Time D (Default = 900 Seconds)	17116

Specify how long (in-seconds) outputs are activated when the response is set to one-shot.

#### Note

Only those outputs programmed to be one-shot (A, B, C, or D) will be affected by this setting.

### To Program One-Shot Time:

1. Enter the desired item number.
2. Enter the desired one-shot time duration (1–999) and press #.

Output Delay Time (Default = 30 Seconds)	17112
---------------------------------------------	-------

Specify how long (in-seconds) output activation is delayed.

#### Note

Only those outputs that are programmed to be delayed will be affected by this setting.

### To Program the Output Delay Time:

1. Enter the desired item number.
2. Enter the desired delay time (1–999) and press #.

## Accessory Modules

The items below allow you to add, delete, list, and modify SuperBus 2000 devices and settings.

Add (Learn) Bus Devices Default = NA	48001
-----------------------------------------	-------

Use this item number to force the panel to scan for bus devices once they have been correctly connected to the panel.

#### Note

All SuperBus 2000 devices are added to partition/area 1 initially. Use item number 48004 (Bus Device Partition/Area) to assign devices to different partitions/areas once added.

### To Force the Panel to Scan for Bus Devices:

Once in program mode enter 48001. The display will show DEVICES ADDED, then it will list the added devices as shown.

DEVICE nn ID xxxxxxxx PARTITION/AREA Z

Where n is the 2-digit device number (01–62), xxxxxxxx is the 8-digit ID number (address), and Z is the partition/area number (1–8).

**Delete/Change Bus Device ID** 48002  
 Default = NA

Use this item number to delete bus devices or change device IDs (replace one device with a new one). If you are deleting bus devices, you must delete them one at a time.

**Note**

Deleting the device does not delete the bus text associated with the deleted device. To delete device text use item number 49002.

**To Delete/Change Device ID:**

1. Once in program mode enter 48002. The display shows ENTER DEVICE ID OR PRESS \* TO CANCEL.
2. Enter the 8-digit device ID of the device you wish to delete/change (located on module) and press #.
3. The display shows ENTER NEW DEVICE ID OR ENTER 0 TO DELETE.
4. Enter a new device ID or enter 0.
5. Press #. The panel displays DEVICE ID XXXXXXXX DELETED, or DEVICE CHANGE OK.
6. To delete/change another device ID, repeat the above procedure.

**Bus Device Text** 49002  
 Default = None

Use the following guidelines to “name” bus devices:

- Use the item numbers that appear in Table B2 on page 85 for characters and words listed there.
- If a desired word does not appear in Table B2, create it using the characters (custom text).
- When using words from Table B2, spaces between them appear automatically. When using characters from Table B2 to create words, you must reserve an item number for a ‘space’ after the word.
- Each character or word uses up one item number. For example, a word from the list counts as one item number. A created word (such as BOY’S) counts as six item numbers—4 letters, 1 apostrophe, and 1 space.
- Only 8 item numbers are allowed for each bus device name, so plan ahead before programming device text. You may need to abbreviate words to avoid running out of item numbers.

**To Program Device Text:**

1. Once in program mode enter 49002. The display shows ENTER DEVICE ID OR PRESS \* TO CANCEL.
2. Enter the desired device ID (located on module) and press #. The display shows TEXT FOR DEVICE XXXXXXXX IS CURRENT TEXT. ENTER TEXT NUMBERS OR PRESS # TO ACCEPT.
3. Enter the numbers of the desired characters or words. If you make a mistake press \* to start over.
4. Once all numbers have been entered, press # to accept. The display shows the new device text.

**To Delete Device Text:**

1. Once in program mode enter 49002. The display shows ENTER DEVICE ID NUMBER OR PRESS \* TO CANCEL.
2. Enter the desired device ID number and press #. The display shows TEXT FOR DEVICE XXXXXXXX IS CURRENT TEXT. ENTER TEXT NUMBERS OR PRESS # TO ACCEPT.
3. Enter 000 and press #. The display shows TEXT FOR DEVICE XXXXXXXX IS NO TEXT.

**List Bus Devices** 48003  
 Default = NA

Use this item number to list information about existing bus devices. The system will list the device address number, device ID number, and the partition/area number.

**To List Bus Devices:**

Once in program mode enter 48003. The display will show DEVICE nn, ID XXXXXXXX, PARTITION/AREA n.

The panel will scroll through and display information about each device. To skip forward press #. To exit press \*. Once the panel lists all the bus devices it will return to the program menu.

**Bus Device Partition/Area** 48004  
 Default = NA

Use this item number to assign bus devices to partitions/areas.

**Note**

All bus devices default to partition/area 1.

**To Assign Bus Devices to Partition/Area:**

1. Once in program mode enter 48004. The display shows ENTER DEVICE ID OR PRESS \* TO CANCEL.
2. Enter the 8-digit device ID and press #. The display shows ENTER PARTITION NUMBER OR PRESS \* TO CANCEL.
3. Enter the partition/area number and press #. The display shows DEVICE XXXXXXXX IS IN PARTITION n.

**Note**

If the partition/area is not enabled, the display will show PARTITION nn INVALID. See item number xx068 to enable partition/area(s).

**Change Transmit Bus ID** 48005  
 Default = NA

This item number allows you to change or view the wireless transceiver device ID used to communicate with “buddy” panels and/or wireless 2-way devices.

**To Change/View Transmit Bus ID:**

1. Once in program mode enter 48005. The display shows RADIO ID IS XXXXXXXX, then displays ENTER NEW TRANSMIT ID OR PRESS # TO ACCEPT.
2. Enter the new 8-digit transmit ID or press # to accept the existing ID. The touchpad displays RADIO ID IS XXXXXXXX.

**List Bus Device Text** 48006  
 Default = NA

Use this item number to list existing bus device ID numbers and display text.

**To List Bus Device Text:**

Once in program mode enter 48006. The display will show ID XXXXXXXX ANY DEVICE TEXT.

The panel will scroll through and display information about each device. To skip forward press #. To exit press \*. Once the panel lists all the bus devices it will return to the program menu.

<b>Replace/Delete Bus Device Text ID</b> Default = NA	<b>48007</b>
Changes (overwrites) the bus device text with that of another bus device.	
<b>To Replace/Delete Bus Device ID:</b>	
1. Once in program mode enter 48007. The display shows ENTER DEVICE ID OR PRESS * TO CANCEL.	
<p style="margin-left: 20px;"><b>Note</b> If the display shows DEVICE XXXXXXXX INVALID, there is no device text associated with the device ID you entered.</p>	
2. Enter the 8-digit device ID of the device you wish to replace/delete (located on module) and press #.	
3. The display shows ENTER NEW DEVICE ID OR ENTER 0 TO DELETE.	
4. Enter the new device ID or enter 0. Press #.	

<b>Program LED Module</b> Default = NA	<b>48009</b>
Use this item number to program LED modules (driver boards).	
<b>To Program LED Modules:</b>	
1. Once in program mode enter 48009. The display shows ENTER DEVICE ID OR PRESS * TO CANCEL.	
2. Enter the 8-digit device ID number and press #. The display shows ENTER LED NUMBER OR PRESS * TO CANCEL.	
3. Enter the desired LED number (1–128) and press #. The display shows LED TYPE IS N. ENTER NEW LED TYPE OR PRESS # TO ACCEPT.	
4. Enter the desired LED type (0–15) from Table B10 on page 100 and press #. The display shows LED DATA IS N. ENTER NEW LED DATA OR PRESS # TO ACCEPT.	
5. Depending on the LED type, enter the desired LED data (see Table B10) and press #.	
6. To program another LED group, go back to step 1. To exit back to the program menu, press *.	

<b>Delete/Replace LED Module</b> Default = NA	<b>48010</b>
Use this item number to delete LED modules or change device IDs. This setting allows you to replace a malfunctioning LED module without having to reprogram LED settings.	
<b>To Delete/Replace LED Module:</b>	
<p style="margin-left: 20px;"><b>Note</b> Deleting the module does not delete the bus text associated with the deleted device. To delete device text use item number 49002.</p>	
1. Once in program mode enter 48010. The display shows ENTER DEVICE ID OR PRESS * TO CANCEL.	
2. Enter the 8-digit device ID of the device you wish to delete or replace (located on module) and press #.	
3. The display shows ENTER NEW DEVICE ID OR ENTER 0 TO DELETE.	
4. Enter a new device ID or enter 0. Press #. The panel displays DEVICE ID XXXXXXXX DELETED, OR DEVICE CHANGE OK.	
5. To delete or replace another LED module, repeat the above procedure.	

<b>Keypad Idle Text</b> Default = None	<b>49005</b>
Use the following guidelines to add keypad idle text to the panel. This is the custom text displayed when the partition/area is not armed, not in alarm, and not in a trouble condition.	
<ul style="list-style-type: none"> <li><input type="checkbox"/> Use the item numbers that appear in Table B3 on page 91 (2 digit display descriptors) for characters.</li> <li><input type="checkbox"/> When using characters from Table B3 to create words, you must reserve an item number for a 'space' after the word.</li> <li><input type="checkbox"/> Each character or word uses up one item number. For example a word (such as EAST WING) counts as nine item numbers—8 letters and 1 space.</li> <li><input type="checkbox"/> 63 item numbers are reserved for display text in each partition/area so plan ahead before programming text. You may need to abbreviate words to avoid running out of item numbers.</li> </ul>	
<b>To Program Keypad Idle Text:</b>	
1. Once in program mode enter 49005. The display shows ENTER PARTITION/AREA NUMBER OR PRESS * TO CANCEL.	
2. Enter the desired partition/area number and press #. The display shows ENTER DISPLAY NUMBERS OR PRESS * TO CANCEL.	
3. Enter the numbers of the desired characters. If you make a mistake press * to start over.	
4. Once all numbers have been entered, press #.	
<b>To Delete Keypad Idle Text:</b>	
1. Once in program mode enter 49005. The display shows ENTER PARTITION NUMBER OR PRESS * TO CANCEL.	
2. Enter the desired partition/area number and press #. The display shows ENTER DISPLAY NUMBERS OR PRESS * TO CANCEL. Press #.	

### Programmable Output Settings

**Note**  
Whenever possible, use Advent Downloader to program outputs.

All non-X-10 outputs must be mapped to the desired bus module, SnapCard, or panel relay/general purpose output. Due to the complexity of this procedure, it is recommended to program outputs using Advent Downloader. Output text may easily be programmed at a panel touchpad.

**Output Configuration** 50005  
 Default = NA

Use the procedure below for mapping outputs.

**To Program an Output:**

1. Once in program mode enter 50005. The display shows ENTER OUTPUT NUMBER OR PRESS \* TO CANCEL.
2. Enter the desired 3-digit output number from the following choices:
  - 001 - 100, programmable outputs.
  - 501–504/508, Interior siren outputs (1 per partition/area).
  - 601–604/608, Exterior siren outputs (1 per partition/area).
  - 701–704/708, Strobe outputs (1 per partition/area).
3. Press #. The display shows OUTPUT TYPE IS n. ENTER NEW TYPE OR PRESS # TO ACCEPT.
4. Enter the output type from the following choices:
  - Enter 1 for a Bus Module Output.
  - Enter 3 for a SnapCard Output.
  - Enter 4 for an Panel Output.
5. Press #. The display shows OUTPUT DATA n IS nnnnnnnn. ENTER OUTPUT DATA n OR PRESS # TO ACCEPT.
6. Based on the output type, enter the required data from the choices below.

**Bus Module Output**

Enter the 8-digit device ID and press #.

Enter 1 + # for output data 4. Output data 5 shows 00000000. The first 4 places represent outputs 1-4 on a 4 Relay Output Module.

Choose which output(s) to activate. For example, entering 10010000 activates outputs 1 and 4 on a 4 Relay Output Module.

**SnapCard Output**

Output data 5 shows 00000000. The first 4 places represent an output SnapCard mounted in the lower slot (SnapCard 1). The last 4 places represent an output SnapCard mounted in the side slot (SnapCard 2).

Choose which output(s) to activate. For example, entering 01000010 would activate the second output on SnapCard 1, and the third output on SnapCard 2.

**Panel Output**

Output data 5 shows 00000000. The first 6 places represent general purpose outputs 1–6, 7 represents the panel interior siren output, and 8 represents the panel exterior siren output.

Choose which output(s) to activate. For example, entering 11000000 activates onboard outputs 1 and 2.

**Menu Output Text** 49003  
 Default = None

Use the following guidelines to “name” the X-10 and non-X-10 menu output numbers that appear in the “Lights/Devices” user menus.

- Use the item numbers that appear in Table B2 on page 85 for characters and words listed there.
- If a desired word does not appear in Table B2, create it using the characters (custom text).

**Note**

Only preprogrammed words from Table B2 can be spoken by the panel. Silence takes the place of any created words when the panel voice speaks. However, created words are displayed just like preprogrammed words.

- When using words from Table B2, spaces between them appear automatically. When using characters from Table B2 to create words, you must reserve an item number for a ‘space’ after the word.
- Each character or word uses up one item number. For example, a word from the list counts as one item number. A created word (such as BOY’S) counts as six item numbers—4 letters, 1 apostrophe, and 1 space.
- Only 8 item numbers are allowed for each output name, so plan ahead before programming output text. You may need to abbreviate words to avoid running out of item numbers.

**To Program Output Text:**

1. Once in program mode enter 49003. The display shows ENTER OUTPUT NUMBER OR PRESS \* TO CANCEL.
2. Enter the desired output number as follows:
  - Partition 1—1 thru 40
  - Partition 2—41 thru 80
  - Partition 3—81 thru 120
  - Partition 4—121 thru 160
  - Partition 5—161 thru 200
  - Partition 6—201 thru 240
  - Partition 7—241 thru 280
  - Partition 8—281 thru 320

**Note**

Entering an output number outside the range for a given partition is indicated by an “Invalid” message.

3. Press #. The display shows TEXT FOR OUTPUT nn IS CURRENT TEXT. ENTER TEXT NUMBERS OR PRESS # TO ACCEPT.
4. Enter the numbers of the desired characters or words. If you make a mistake press \* to start over.
5. Once all numbers have been entered, press # to accept. The display shows the new output text.

**To Delete Output Text:**

1. Once in program mode enter 49003. The display shows ENTER OUTPUT NUMBER OR PRESS \* TO CANCEL.
2. Enter the desired output number and press #. The display shows TEXT FOR OUTPUT nn IS CURRENT TEXT. ENTER TEXT NUMBERS OR PRESS # TO ACCEPT.
3. Enter 000 and press #. The display shows TEXT FOR OUTPUT nn IS NO TEXT.

## Alarm Settings

Alarm settings specify how the panel behaves during certain alarm situations. Alarm settings are global.

### Alarm Messages Played at High Volume 17079 Default = 1 (On)

Choose whether or not you want alarm messages (on voice siren) *always* played at high volume. If not, they will be played at normal volume.

**Note**

Auxiliary/Medical alarm messages are never sounded at high volume regardless of this setting.

**To Set Alarm Message Volume:**

1. Once the item number has been entered, enter 1 for on (high volume), or 0 for off (normal volume).
2. Press # to apply the new setting.

### Evacuation Messages 17083 Default = 0 (Off)

Choose whether or not fire alarm evacuation audio messages are played during fire alarms. If off, evacuation messages will not play during fire alarms.

**To Turn Evacuation Messages On/Off:**

1. Once the item number has been entered, enter 1 for on, or 0 for off.
2. Press # to apply the new setting.

### Evacuation Message Count 17104 Default = 4 Messages

Set the number of evacuation messages (0–4) to be played. Evacuation messages are automatically played until the siren times out, the alarm is silenced, or the alarm is canceled. This setting determines the number of evacuation messages played starting with number 1 and up (then repeated). For example, if set to 2, evacuation messages 1 and 2 will be played and repeated.

**Note**

In order for the panel to play evacuation messages during fire alarms, the Evacuation Messages setting (17083) must be set to “on”.

**To Set Evacuation Message Count:**

Once the item number has been entered, enter the evacuation message count (0–4) and press #.

### First Fire Alarm Disarm/Silence 17084 Default = Off

When set to on, the first code entry will silence a fire alarm and the second code entry will cancel the alarm. If off, the first code entry will silence *and* cancel the alarm.

**To Turn First Fire Alarm Disarm/Silence On/Off:**

1. Once the item number has been entered, enter 1 for on, or 0 for off.
2. Press # to apply the new setting.

### Unsilence Alarm 17126 Default = 0 (Off)

Choose whether or not to enable unsilencing of alarm after silencing period expires. If on, a silenced fire alarm will resound.

**Note**

The silencing period can be set using the Time Fire Alarm is Silenced setting (17111) below.

**To Turn Unsilence Alarm On/Off:**

1. Once the item number has been entered, enter 1 for on, or 0 for off.
2. Press # to apply the new setting.

### Time Fire Alarm is Silenced 17111 Default = 30 Seconds

Specify the amount of time (in seconds), for which sirens are silenced during a fire alarm (after a user enters a valid access code).

**Note**

The alarm will not unsilence if Unsilence Alarm setting (17126) is set to off.

**To Set Time Fire Alarm is Silenced:**

1. Once the item number has been entered, specify the silence time (15–999).
2. Press # to apply the new setting.

### Annunciate Earliest Fire Alarm 17128 Default = 0 (Off)

If on, the panel will annunciate the earliest active fire alarm instead of the most recent, during a multiple fire alarm situation.

**Note**

This option is intended for panels installed in Canada.

**To Turn Annunciate Earliest Fire Alarm On/Off:**

1. Once the item number has been entered, enter 1 for on, or 0 for off.
2. Press # to apply the new setting.

### Medical Alarm Sound Rhythm 17046 Default = 3 (Alternate Modulated)

### Police Siren Cadence 17047 Default = 5 (Steady)

### Auxiliary Alarm Sound Rhythm 17048 Default = 4 (Fast Modulated)

Set the alarm type to the desired sound rhythm.

Sound Rhythm Format ( \_ represents 0.125 second sound, \_\_\_ represents 0.5 second sound).

- 1— Temporal 3 \_ \_ \_ (silence) (repeat)
- 2— Modulated \_ \_ \_ \_ (repeat)
- 3— Alternate Modulated \_ \_ \_ \_ (repeat)
- 4— Fast Modulated \_ \_ \_ \_ \_ (repeat)
- 5— Steady \_ \_ \_ \_ \_ (steady on)
- 6— Programmable (must program through downloader)

**To Set Alarm Sound Rhythm:**

1. Once in program mode enter the desired item number.
2. Enter the desired sound rhythm (1–6) and press #.



## System Settings

### Note

Date, time, and day settings affect all partitions/areas.

System Date	17001
Default = 01 01 00 (1/1/00)	
This setting lets you adjust the panel calendar to the correct month, day, and year.	
<b>To Set the System Date:</b>	
<ol style="list-style-type: none"> <li>1. Enter the item number.</li> <li>2. Enter the correct month (01–12), day (01–31), and year (00–99). For example, enter 090100 for September 1, 2000.</li> <li>3. Press #. The display shows the new date.</li> </ol>	

System Time	17002
Default = 12 00 00 (12:00:00)	
This setting lets you adjust the panel clock to the correct time. The panel uses a 24-hour clock. For example, to set the time to 4:17:00 PM, enter 161700.	
<b>To Set the System Time:</b>	
<ol style="list-style-type: none"> <li>1. Enter the item number.</li> <li>2. Enter the correct time 00(0000–235959).</li> <li>3. Press #. The display shows the new time.</li> </ol>	

System Day of Week	17003
Default = 5 (Saturday)	
This setting lets you adjust the panel to the current day of week.	
<p><b>Note</b> Day of week is automatically set when system date is set (for dates in 21st century).</p>	
Day Format:	
<input type="checkbox"/> 0—Monday <input type="checkbox"/> 4—Friday <input type="checkbox"/> 1—Tuesday <input type="checkbox"/> 5—Saturday <input type="checkbox"/> 2—Wednesday <input type="checkbox"/> 6—Sunday <input type="checkbox"/> 3—Thursday	
<b>To Set the System Day of Week:</b>	
<ol style="list-style-type: none"> <li>1. Enter the item number.</li> <li>2. Enter the day of week using the above format (0–6) and press #.</li> </ol>	

Time Format	17100
Default = 0 (Off)	
This setting allows you to choose whether the panel time format is in 12- (AM and PM) or 24-hour format. If on, the panel will announce and display the time in 24-hour format.	
<b>To Turn Time Format On/Off:</b>	
<ol style="list-style-type: none"> <li>1. Once the item number has been entered, enter 1 for on, or 0 for off.</li> <li>2. Press # to apply the new setting.</li> </ol>	

Detect Receiver Failure	17078
Default = 1 (On)	
When on, (and a wireless commercial transceiver is installed), the panel will detect and indicate wireless receiver failure. This means the panel has received no messages from any wireless zone for 2 hours.	
<b>To Turn Detect Receiver Failure On/Off:</b>	
<ol style="list-style-type: none"> <li>1. Once the item number has been entered, enter 1 for on, or 0 for off.</li> <li>2. Press # to apply the new setting.</li> </ol>	

Downloader Callback	17122
Default = 0 (Off)	
Select whether or not to have the panel call back the downloader when the downloader calls out to the panel with a job. This increases security of the downloader sessions by insuring that all downloads are performed by a Downloader that is connected to one of the panel's programmed Downloader phone numbers.	
<b>To Turn Downloader Callback On/Off:</b>	
<ol style="list-style-type: none"> <li>1. Once the item number has been entered, enter 1 for on, or 0 for off.</li> <li>2. Press # to apply the new setting.</li> </ol>	

Phone Off-Hook is Activity	17092
Default = 1 (On)	
Select whether or not a phone off-hook condition is considered an activity. See no activity internal (xx009)	
<p><b>Note</b> For residential use only.</p>	
<b>To Turn Phone Off-Hook is Activity On/Off:</b>	
<ol style="list-style-type: none"> <li>1. Once the item number has been entered, enter 1 for on, or 0 for off.</li> <li>2. Press # to apply the new setting.</li> </ol>	

RF Supervisory Time A	17049
(Default = 4 Hours - Commercial Burg, 24 Hours - Home Navigator)	
RF Supervisory Time B	17050
(Default = 24 Hours- Commercial Burg, 4 Hours - Home Navigator)	
The RF Supervisory Time is the time (in hours) in which the panel must receive a transmission from a wireless zone. If the panel does not receive a transmission within this time window, a trouble report occurs. Advent panels have two RF Supervisory Times (A and B). All wireless zones default to using Supervisory Time A. Use 47004 to change Supervisory Time.	
<b>To Set RF Supervisory Time:</b>	
<ol style="list-style-type: none"> <li>1. Enter the desired item number.</li> <li>2. Enter the RF Supervisory Time in hours (2–24).</li> <li>3. Press # to apply the new setting.</li> </ol>	

**Automatic Battery Test Interval** 17073  
**Default = 1 (4 Hours)**

Select the time interval between automatic battery tests:  
 1 = 4 hours     0 = 24 hours

**To Set Automatic Battery Test Interval:**

1. Once the item number has been entered, enter 1 for every 4 hours, or 0 for every 24 hours.
2. Press # to apply the new setting.

**High Rise Installation** 17074  
**Default = 0 (Off)**

Set to "on" when the panel is installed in a high rise building. This will enable zones to have "floor" attributes. When on, any zone not programmed with a floor attribute will *not* turn on all outputs with a "fire on floor" condition programmed. When off, any zone not programmed with a floor attribute *will* turn on all outputs with a "fire on floor" condition programmed.

**To Turn High Rise Installation On/Off:**

1. Once the item number has been entered, enter 1 for on, or 0 for off.
2. Press # to apply the new setting.

**Commercial/Residential Option** 17076  
**Default = 0 (Home Navigator), 1 (Commercial)**

This option controls the names of arming levels 2 and 3. When set to commercial (1), level 2 is called Perimeter, level 3 is called Full. When set to residential (0), level 2 is Home and level 3 is Away.

1 = 4 hours     0 = 24 hours

**To Set commercial/residential option:**

1. Once the item number has been entered, enter 1 for commercial, or 0 for residential.
2. Press # to apply the new setting.

**Report System Events** 17096  
**Default = 1 (On)**

This setting determines if system events are reported to the central station.

**To Turn Report System Events On/Off:**

1. Once the item number has been entered, enter 1 for on, or 0 for off.
2. Press # to apply the new setting.

**System Report Time (STIME)** 17004  
**Default = Random**

Enter the time of day (in 24-hour format) when an automatic phone test to the central station is performed.

**To Set the System Report Time:**

1. Enter the desired item number.
2. Enter the 4-digit system report time (00:00-23:59) and press # to apply the new setting.

**Enable RF Jam Detect** 17072  
**Default = 1 (On)**

Select whether or not the panel will detect an RF jam. If enabled, a RF Jam trouble condition will be generated whenever the background noise level exceeds the received signal strength for any wireless zone.

**Note**  
 This setting must be set to "on" in commercial fire and burglary systems.

**To Turn RF Jam Detect On/Off:**

1. Once the item number has been entered, enter 1 for on (jam detection), or 0 for off (no jam detection).
2. Press # to apply the new setting.

**Long Range Radio** 17075  
**Default = 0 (Off)**

Select whether or not you want to enable long range radio (if connected to panel).

**Note**  
 This option can only be programmed through Advent Downloader.

**Percent Full History Buffer Reports** 17043  
**Default = 80 Percent**

This setting allows you to specify how full (percent) the history buffer may get before generating history buffer full trouble condition. Another trouble is generated when the history buffer overflows.

**To Set History Buffer Percent:**

1. Once in program mode enter the item number.
2. Enter the desired percentage (10-100) and press #.

**Percent Full Report Buffer Reports** 17044  
**Default = 80 Percent**

This setting allows you to specify how full (percent) the report buffer gets before forcing early reporting of delayed low priority events. No trouble is generated until the report buffer overflows.

**To Set Report Buffer Percent:**

1. Once in program mode enter the item number.
2. Enter the desired percentage (10-100) and press #.

**Partition/Area Text Speech** 17125  
**Default = 1 (On)**

If on, partition/area text (49004) will be displayed on touchpads and spoken over speakers. If off, partition/area text will only be displayed on touchpads.

**To Turn Partition/Area Text Speech On/Off:**

1. Once the item number has been entered, enter 1 for on, or 0 for off.
2. Press # to apply the new setting.

**Enable Daylight Savings Time Adjust** 17070  
 Default = 1 (On)

This setting allows you to select whether or not the panel adjusts to daylight savings time. If on, the clock makes daylight savings adjustments at 2:00 AM on the first Sunday in April and the last Sunday in October. The time will spring ahead from 01:59 to 03:00 or fall back from 01:59 to 01:00.

**To Turn Daylight Savings Time Adjust On/Off:**

1. Once the item number has been entered, enter 1 for on, or 0 for off.
2. Press # to apply the new setting.

**Print System Events** 17099  
 Default = 1 (On)

This setting allows you to select whether or not to print system events.

**Note**

This setting only enables the printing of *system* events. See Print Partition/Area Events setting (xx091) to enable partition/area event printing.

**To Turn Print System Events On/Off:**

1. Once the item number has been entered, enter 1 for on, or 0 for off.
2. Press # to apply the new setting.

**Print Line Feed after Carriage Return** 17097  
 Default = 1 (On)

This setting allows you to select whether or not to print a line feed after a carriage return. This will tell the printer to print a line feed, creating an extra blank line.

Some printers have an auto line feed setting. If the printer adds its own extra line feed, disable this setting so that it doesn't print extra blank lines. Check the printer manual for details.

**To Turn Print Line Feed after Carriage Return On/Off:**

1. Once the item number has been entered, enter 1 for on, or 0 for off.
2. Press # to apply the new setting.

**Printer Supports Epson ESC/P Protocol** 17124  
 Default = 1 (On)

Turn this setting on if the printer attached to the panel supports ESC/P protocol. Check the printer manual for details.

**To Turn Epson ESC/P Protocol On/Off:**

1. Once the item number has been entered, enter 1 for on, or 0 for off.
2. Press # to apply the new setting.

**AC Report Delay** 17041  
 Default = 6 Hours

This setting allows you to select the hours to delay (in addition to random 0–30 minute delay) before the panel reports AC power failure to the central station.

**To Set AC Report Delay:**

1. Once in program mode enter the item number.
2. Enter the desired delay (0–36) and press #.

**Low Battery Voltage** 17037  
 Default = 180 (10.6V)

This setting allows you to specify the backup battery voltage at which low battery trouble is generated (set in 1/17 volt units).

**To Set Low Battery Voltage:**

1. Once in program mode enter the item number.
2. Enter the desired voltage (172–188 [10.1–11.1V]) and press #.

**Battery Restored Voltage** 17038  
 Default = 196 (11.6V)

This setting allows you to set the voltage at which a low battery trouble restoral is generated (set in 1/17 volt units).

**To Set Battery Restoral Voltage:**

1. Once in program mode enter the item number.
2. Enter the desired voltage (188–204 [11.1–12.0V]) and press #.

**Start Shutdown Battery Voltage** 17039  
 Default = 159 (9.4V)

This setting allows you to set the backup battery voltage at which a system shutdown (during an AC power failure) is started (set in 1/17 volt units).

**To Set Start Shutdown Voltage:**

1. Once in program mode enter the item number.
2. Enter the desired voltage (151–167 [8.9–9.8V]) and press #.

**Cancel Shutdown Battery Voltage** 17040  
 Default = 176 (10.4V)

This setting allows you to set the backup battery voltage at which a system shutdown (during an AC power failure) is canceled (set in 1/17 volt units).

**To Set Cancel Shutdown Voltage:**

1. Once in program mode enter the item number.
2. Enter the desired voltage (168–184 [9.9–10.8V]) and press #.

**AC Stable Time** 17036  
**Default = 8 Seconds**

This setting allows you to specify the time (in seconds) that AC power must be lost or restored before a trouble, or trouble restoral is generated. These events are not reported immediately (see 17041).

**To Set AC Stable Time:**

1. Once in program mode enter the item number.
2. Enter the desired time (0–200) and press #.

**AC Frequency** 17123  
**Default = 0 (60 Hz)**

This setting allows you to choose the AC frequency that is powering the panel.

**To Set the AC Frequency:**

1. Once in program mode enter the item number.
2. Enter 1 for 50 Hz (off), or 0 for 60 Hz (on).
3. Press # to apply the new setting.

**Latitude Adjustment** 17110  
**Default = 0 Degrees**

This setting allows you to specify the latitude (in degrees) where the panel is located. This information is then used by the panel when automatically adjusting sunrise/sunset schedules.

**To Set the Latitude:**

1. Once in program mode enter the item number.
2. Enter the desired latitude (0–65) and press #.

**On Premises Pager ID 1** 17060  
**On Premises Pager ID 2** 17061  
**Defaults = 0000000**

This setting allows you to specify 7-digit pager IDs that will identify the 2 different pager groups in a local paging network.

**To Specify On Premises Pager IDs:**

1. Once in program mode enter the item number.
2. Enter the desired 7-digit (0–9) pager ID and press #.

**Miscellaneous Settings**

**Downloader Account Number** 17109  
**Default = 00000000**

The Downloader Account Number is used to identify the panel to Advent Downloader.

**To Enter a Downloader Account Number:**

1. Once the desired item number has been entered the current account number will be displayed.
2. Enter an 8-digit number (0–9) and press #.

**Reset Panel** 50001  
**Default = NA**

This setting allows you to clear any errors the panel may have by “rebooting” the system. All settings will remain unchanged.

**To Reset the Panel:**

1. Enter the installer code.
2. Enter 50001.
3. Press 99 and then #. Wait about a minute for the panel to reset.

**Software/Hardware Version** 50003  
**Default = NA**

This setting allows you to view and identify panel hardware and software version.

**To View System Version:**

1. Enter the installer code.
2. Enter 50003. The panel displays SYSTEM ID nnnnnnnn VERSION n.nn nnn.nnn PANEL TYPE n SNAPCARD n n.

Panel Type Formats:

0—Commercial Burg-250	5—not used
1—Home Navigator-132	6—not used
2—Commercial Fire-250	7—Commercial Burg-132
3—Home Navigator-250	8—Commercial Fire-132
4—not used	

SnapCard Type Formats:

0—none	5—quad smoke loop
1—not used	6—not used
2—NAC	7—not used)
3—8Z input	8—4z input, 2 relay output
4—4 relay output	

**Clear History Buffer** 50004  
**Default = NA**

This setting allows you to clear the history buffer.

**To Clear History Buffer:**

1. Enter the installer code.
2. Enter 50004. The display shows HISTORY BUFFER CLEARED.

**Set Holiday A List** 50008  
**Set Holiday B List** 50009  
**Defaults = NA**

Holiday lists allow you to set up time periods when regular schedule hours vary. A holiday is defined as one day. A separate holiday must be added in order to span over consecutive days. Once set up, users can incorporate holidays into schedules. Each partition/area has 2 lists (A and B) and each list has up to 8 holidays. Document holidays in the *User's Guide*.

**To Add a Holiday:**

1. Enter the installer code.
2. Enter the desired item number. The display shows ENTER PARTITION/AREA NUMBER OR PRESS \* TO CANCEL.
3. Enter the partition/area number (1–8) and press #. The display shows ENTER HOLIDAY NUMBER OR PRESS \* TO CANCEL.
4. Enter the desired holiday number (1–8) and press #. The panel display shows HOLIDAY DATA IS CURRENT DATA.
5. Enter a 2-digit month (01–12), a 2-digit day (01–31), and press #. For example, if the holiday fell on July 4, you would enter 0704.
6. The display shows the new holiday setting.

**To Delete a Holiday:**

1. Enter the installer code.
2. Enter the desired item number. The display shows ENTER PARTITION/AREA NUMBER OR PRESS \* TO CANCEL.
3. Enter the partition/area number (1–8) and press #. The display shows ENTER HOLIDAY NUMBER OR PRESS \* TO CANCEL.
4. Enter the desired holiday number (1–8) and press #. The panel display shows HOLIDAY DATA IS current data.
5. Enter 0 + #. The display shows HOLIDAY DATA IS NO DATA.

**Set Event Configuration and Alarm Masks** 50010  
**Defaults = NA**

This setting allows you to specify how you want events reported.

**Note**

Whenever possible, use Advent Downloader to set configuration masks.

Event masks are represented by an eight-digit event mask number where 0 = off and 1 = on. For example, if an event mask reported to phone 1, phone 2, history buffer, and was high priority, it would be represented as "11010001" (see event mask formats below). If you wanted the same event mask to stop reporting to phone 2, you would change the event mask number to "10010001." Notice how the place holder for phone 2 was changed from a 1 (on) to a 0 (off). (From 11010001 to 10010001).

**Event Mask Formats:**

1—Reporting Phone 1	5—Pager
2—Reporting Phone 2	6—Report to Backup
3—Print	7—(not used)
4—History Buffer (Store)	8—High Priority

**To Set a Configuration Mask:**

1. Enter 50010. The display shows ENTER EVENT GENERAL TYPE OR PRESS \* TO CANCEL.
2. Enter the event general type (1–19) using Table B8 on page 97, then press #. The display shows ENTER EVENT SPECIFIC TYPE OR PRESS \* TO CANCEL.
3. Enter the event specific type using Table B8, and press #. The display shows ENTER PARTITION NUMBER OR PRESS \* TO CANCEL.
4. Enter the desired partition/area (1–8) and press #. The display shows the eight-digit event mask, then ENTER NEW EVENT MASK OR PRESS # TO ACCEPT.
5. Enter the desired 8-digit event mask (0 = off, 1 = on, and 2 = unchanged), then press #.

**Alarm Event Formats:**

1—Not Used	5—(leave at default)
2—Not Abortable	6—(leave at default)
3—Reporting Delay (part 1)*	7—(leave at default)
4—Reporting Delay (part 2)*	8—(leave at default)

**Reporting Delay Formats:**

00 = Immediate, 01 = Fire delay, 10 = Panic delay, 11 = Standard delay.

**To Set an Alarm Event:**

1. Enter 50010. The display shows ENTER EVENT GENERAL TYPE OR PRESS \* TO CANCEL.
2. Enter the event general type (0) and then press #. The display shows ENTER EVENT SPECIFIC TYPE OR PRESS \* TO CANCEL.
3. Enter the alarm specific type using Table B8, and press #. The display shows ENTER PARTITION NUMBER OR PRESS \* TO CANCEL.
4. Enter the desired partition/area (1–8) and press #. The display shows the eight-digit event mask, then ENTER NEW EVENT MASK OR PRESS # TO ACCEPT.
5. Enter the desired 8-digit event mask (0 = off, 1 = on, and 2 = unchanged), then press #.

**Print Zone & Device Information** 50012  
**Default = NA**

Sends programmed zone and device information to the printer.

**To Print Zone and Device Information:**

Enter 50012. Zone and Device information will print.

<b>Print History Buffer</b> Default = NA	<b>50016</b>
Prints events based on a time range.	
<b>To Print History Buffer:</b>	
1. Enter 50016. The display shows ENTER HISTORY START.	
2. Enter the desired start date in mm/dd/yy format. For example, if you wanted to print events starting on September 1, 1999 you would enter 090199. The display shows ENTER HISTORY STOP.	
3. Enter the desired stop date in mm/dd/yy format. Events occurring within that time frame will print.	

<b>Delete Primary SnapCard</b> <b>Delete Secondary SnapCard</b> Default = NA	<b>50014</b> <b>50015</b>
This setting enables you to delete a SnapCard when it is being replaced with a different type of SnapCard. All inputs/outputs for the new card must be programmed.	
<b>Note</b> If you are replacing the SnapCard with the same type of SnapCard you don't have to perform this procedure and can keep the current input/output settings.	
<b>To Delete SnapCard Information:</b>	
1. Enter the installer code.	
2. Enter the desired item number. The panel displays SNAPCARD DELETED.	

## Remote Downloader Programming

Although most information can be programmed at the panel, some optional information must be programmed remotely from Advent Downloader. Use the information you recorded in Appendix A to inform the downloading operator of the programming requirements for this system.

### Advent Downloader Programming

**Note**

The Enable Remote Access setting (17086) must be set to "on" to allow a remote downloader to call in and connect to the panel.

**To initiate an upload/download session from the panel:**

- Contact your download station and ask the operator to prepare for an upload/download session.
- Make sure the panel is connected to a phone line and that premises telephones are on hook (hung up).
- Enter panel programming and verify/enter the following downloader settings:
  - 17107 Dealer Access Code—Must match (in Advent Downloader *and* at the panel) or be left at default.
  - 17108 Downloader Access Code—Must match (in Advent Downloader *and* at the panel) or be left at default.
  - 17109 Downloader Account Number—Must match (in Advent Downloader *and* at the panel) or be left at default.
  - yy001 (23001 or 24001) Phone Number Enable—Must be "on" for panel to call the downloader.

- yy002 (23002 or 24002) Phone Number—At least one downloader phone number must be programmed for panel to call downloader. (Programming the phone number automatically enables it.)

- Enter 0 + 2 + install code (0123 default).
- For an upload enter 1, a download press 2, and a general upload/download press 3. The session will start and the system will return to the previous arming level.

**Note**

The panel software versions (in Advent Downloader *and* at the panel) must match. If the panel displays DOWNLOAD FAILURE contact the downloader station to verify the downloader phone number and settings.

## Installing Line Carrier Devices

This section describes how to install X-10 Lamp, Appliance, and Universal Module line carrier (wireless) line carrier devices.

### Programming the Panel House Code

Please see item numbers xx022 and xx023 for information on setting house codes.

### Installing X-10 Modules

When installing X-10 modules:

- Use only incandescent lamps with lamp modules.
- Do not plug X-10 modules into outlets controlled by a switch.
- Do not use extension cords to connect several lamps or appliances to one module.



**CAUTION**

Use X-10 Lamp Modules to control light fixtures – do not use X-10 Appliance or Universal Modules. Appliance and Universal Modules are not controlled during an alarm.

**To install X-10 modules:**

- Plug the lamp or appliance cord into the bottom of the module.
- Plug the module into a lower AC outlet.
- Refer to Table B4 and B5 on page 91 for the house code you programmed into the panel, and then find the letter that corresponds to that house code. Each letter setting represents one panel house code. For example, house code 1 corresponds with "A" on the X-10 module house dial.
- Set the house dial on the module to the appropriate letter.
- Set the unit number dial from 1 to 16 for the desired response as described in Table B6 on page 92.

### Adding Lights/Devices to Program Memory

**Note**

There are 40 light/device outputs per partition. Light/device numbers 1-32 are X-10 modules. Light/device numbers 33-40 are not X-10 modules and must be mapped to a bus module, snapcard or panel output. Refer to Table B7 on page 93, programming items xx-029 to xx-056 on page 19, and program item 50005 on page 38 for information on programming non-X10 outputs.

**To add lights or devices to program memory:**

1. Press 7. The display shows FEATURES MENU.
2. Enter 3 and the display shows LEARN LIGHTS AND DEVICES.
3. Press 1 to add a light. The panel displays ENTER A LIGHT NUMBER THEN PRESS #.

Press 4 to add a device. The panel displays ENTER A DEVICE NUMBER THEN PRESS #.

4. Enter the desired light or device number (1–40) and press #. The display shows LIGHT/DEVICE nn ADDED.
5. To add another light or device, enter the desired light or device number and press #.
6. To exit press \* + \*.

**To delete lights or devices from program memory:**

1. Press 7. The display shows FEATURES MENU.
2. Enter 3 and the display shows LEARN LIGHTS AND DEVICES.
3. Press 2 to delete a light. The panel displays ENTER A LIGHT NUMBER THEN PRESS #.

Press 5 to delete a device. The panel displays ENTER A DEVICE NUMBER THEN PRESS #.

4. Enter the desired light or device number (1–40) and press #. The display shows LIGHT/DEVICE nn DELETED.
5. To delete another light or device enter the desired light or device number and press #.
6. To exit press \* + \*.

**Testing the System****Note**

Before testing, it is recommended that you have covers on all modules (mounted outside the cabinet) and the panel cabinet door closed. The testing environment should match the system working environment.

This section describes how to perform the following test procedures:

- Basic System Commands.
- Testing Panel Backup Battery(s).
- Testing Hardwired Zone Inputs.
- Testing Wireless Sensors.
- Testing Outputs.
- Testing Optional Lights and Devices (X-10 Modules).
- Testing Phone Communication.
- Testing Central Station Communication.
- Adjusting Touchpad Contrast.

You should test the system after installing, servicing, and adding or removing devices from the system.

Refer “Troubleshooting” on page 50 if correct test results are not achieved.

**Basic System Commands**

Table 12 describes basic touchpad operating commands. For complete details on system operation, including user programming, refer to the system *User Guide*.

**Note**

Refer to Table A12 on page 71 for default access codes.

**Table 12: Basic System Operating Commands**

Command	System Response
1 + 9	Indicates current system status
1 + 1 + CODE	Disarms system to OFF
1 + 2 + CODE	Arms system to PERIMETER/HOME
1 + 3 + CODE	Arms system to FULL/AWAY
8 + 9 + CODE	Manually reset smoke sensors
1 + 0	Check alarm history
7 + 5	Check event history buffer
7 + 7 + CODE + Area	Area jump
8 + 8	Initiates a battery test
8 + 1 + CODE	Initiates a zone test
0 + 1 + CODE	Initiates a phone test
8 + 7 + CODE	Initiates a fire test

**Testing Panel Backup Battery(s)**

The panel can both automatically and manually place a test load on the panel backup battery(s) and measure the voltage output.

**Note**

A newly installed battery may require up to eight hours under panel power before an accurate charge indication.

**To manually test the panel backup battery(s):**

1. Press 8. The display shows SYSTEM MENU.
2. Press 8 again to test the battery(s) and display the result. The display will show the battery voltage as BATTERY TEST: 13.8 V (or similar) TO QUIT PRESS \*.
3. Press \* to end the battery test immediately. The system will automatically ends the battery test after 15 minutes.

**Testing Hardwire and Wireless Zones/Sensors**

It is recommended that you test all hardwired zones and sensors after all programming is completed and whenever a zone/sensor-related problem occurs.

**Note**

While the zone test is a valuable installation and service tool, it only tests zone operation for the current conditions. You should perform a zone test after any change in environment, equipment, or programming.

1. Close and secure the panel door.
2. Make sure all zones and sensors are in their secured (non-alarm) state.
3. Press 8. The display shows SYSTEM MENU.
4. Enter 1 + installer code to initiate the zone test.

5. The display shows ZONE TEST ON - PRESS 11 TO QUIT and sounds one 0.5 second long beep.
6. Actuate/trip and restore each zone/sensor one at a time while monitoring the display.
7. **For hardwire zones** the system will beep and display [ZONE #] TEST GOOD in confirmation. If the system does not respond, check the zone/sensor wiring or panel programming.

**For wireless zones** the system will beep, and indicate [ZONE #] SIGNAL LEVEL [##] to confirm the zone number tested. (Refer to Table 13 for signal level descriptions.) If the system does not respond, or if the sensor does not meet the minimum requirements, refer to the “If a Wireless Sensor Fails the Zone/Sensor Test” section.

8. Press 8 + 2 to view tested zones.
9. Press 8 + 3 to list untested zones.
10. Press 1 + 1 to disarm and end testing (if Quik Arm is on). Otherwise, Press 1 + 1 and enter your installer access code.
11. Repeat this test for each partition/area.

**Table 13: Wireless Signal Levels**

Number	Signal Level
0-5	Weak
6-14	Fair
15-30	Good
31+	Excellent

**If a Wireless Sensor Fails the Zone/Sensor Test**

If system does not beep when a sensor is tripped, place an ITI RF Sniffer (60-401) test tool near the wireless sensor when tripping to verify that the sensor is transmitting. Constant beeps from the RF Sniffer indicate a runaway (faulty) wireless sensor. Remove the sensor battery(s) and replace the sensor.

If possible, locate wireless sensors within 500 feet of the panel. While a transmitter may have a range of one mile or more out in the open, the environment at the installation site can have a significant effect on transmitter range.

Sometimes a change in sensor location can help overcome adverse wireless conditions.

**To improve wireless sensor communication, you can:**

- Reorient the sensor,
- relocate the sensor,
- if necessary, replace the sensor, or
- add additional RF transceivers (up to 5).

**To reorient a wireless sensor:**

1. Rotate the sensor and test for improved sensor communication at 90 and 180 degrees from the original position.
2. If poor communication persists, relocate the sensor as described below.

**To relocate a wireless sensor:**

1. Test the sensor a few inches from the original position.
2. Move the sensor from the original position and retest until an acceptable location is found.
3. Mount the sensor in the new location.
4. If no location is acceptable, replace the sensor as described below.

**To replace a wireless sensor:**

1. Test a known good sensor at the same location.
2. If the transmission beeps remain below the minimum level, avoid mounting a sensor at that location.
3. If the replacement sensor functions, contact ITI for repair or replacement of the problem sensor.

**To add RF transceiver(s):**

Install and wire the RF transceiver module according to the *Installation Instructions* included with the module and the information provided on page 9 of this manual. A total of 5 transceivers may be used.

**Testing Outputs and Sirens**

All outputs (onboard, SnapCard, output module, and X-10) should be tested to verify configuration programming.



**CAUTION**  
Inform the central station of the test *before* activating outputs that trigger from an alarm condition.

1. Contact the central station to inform them you are testing the system.
2. Verify that all wiring at the panel and output devices is correct.
3. Activate the appropriate device to trigger each output as programmed.
4. Verify that each output responds according to the programmed configuration. For outputs that trigger sirens, verify that the correct alarm sounds are produced from these sirens. Table 14 describes the system alarm sounds you should hear from each alarm event (based on defaults).
5. Contact the central station when you are finished testing.

**Table 14: Alarm Types and Sounds**

Alarm Type	Alarm Sound
Fire	Repeating series of three beeps (temporal 3)
Police/Intrusion	Continuous tone
Auxiliary	Rapid beeps

**Testing Lights and Devices (menu controlled outputs)**

Refer to Table B6 in Appendix B for X-10 lamp, appliance, and universal module response operation.



**Note**

Lights and devices must be added (learned) before they can be accessed using the Lights or Devices menus.

**To test lights and devices:**

1. Press 4 to test lights or 5 to test devices. The display shows ENTER A LIGHT/DEVICE NUMBER THEN PRESS #.
2. Enter the desired light or device number to test and press #.
3. Press 1 to select Turn [selected light or device] on now.
4. Verify that the light or device is on.
5. Press 2 to select Turn [selected light or device] off now.
6. Verify that the light or device is off.
7. Press the Lights On or Lights Off buttons twice to turn all lights on the first house code on or off at the same time.

**Note**

Appliance and universal X-10 modules, if any, are all turned off by pressing Lights Off but are not turned on by pressing Lights On.

8. Repeat steps 2–6 for remaining light or device numbers that are used in all partitions/areas.
9. Press \* to return to the main menu.

**Testing Phone Communication**

Perform a phone test to check phone communication between the panel and the central station.

**To perform a phone test:**

1. Contact the central station to inform them that you are testing the system.
2. Make sure all premises telephones are on-hook (hung up).
3. Press 0. The display shows PHONE MENU.
4. Press 1 + primary access code + #. The display shows PHONE TEST.

**Note**

Refer to Table A12 on page 45 for default access codes.

5. Wait for the system to dial and test all programmed telephone numbers.
6. The panel indicates PHONE TEST OK for each phone number successfully tested.
7. Press \* quit the phone test.

**Note**

If NUMBER n TEST FAILURE is indicated, press \* to quit the test and refer to the “Troubleshooting” section.

**Testing Central Station Communication**

After performing zone and phone tests, check that the system is reporting alarms successfully to the central station and pager(s).

**CAUTION**

Be sure to contact the central station before activating outputs/zones that trigger an alarm condition.

**To test communication with the central station:**

1. Call the central station and tell the operator that you will be testing the system.
2. Arm the system.
3. Test each touchpad, wireless panic button, and trip all of the sensors. Verify that the appropriate system indications and alarms are working correctly.
4. Make sure that you test all programmed central station phone numbers, and all partitions/areas.
5. When you finish testing the system, call the central station to verify that all of the correct alarms were received. Check pager displays to verify that reports were received.

**Adjusting Touchpad Display Contrast**

Touchpad displays can be adjusted for easier viewing to help compensate for lighting conditions in the touchpad location. The contrast adjustment lightens or darkens the text.

**Note**

When performing the procedure below you may get a Bus Communication Failure. This is because the panel takes the touchpad off-line when adjusting the contrast.

**To adjust display contrast:**

1. Enter configuration mode by pressing the D and 6 buttons together for at least two seconds. The display shows DA nnn.
2. Press and release the 1 and 2 buttons together repeatedly until the desired contrast level is displayed.
3. Press \* and the display briefly shows DONE, then shows the time and date.

**Note**

For information on adjusting display backlighting and brightness, please see the specific Advent panel User Guide.

Vacuum fluorescent displays do not have a contrast adjustment.

## Troubleshooting

This section describes what to do if you experience problems with system operation. If after performing the troubleshooting procedures the panel still malfunctions, please call Technical Support at 1-800-435-7658.

Feature	Problem	Solution
<b>Access Codes</b>		
	Invalid Code or Invalid Authority is indicated.	<ol style="list-style-type: none"> <li>1. Check that access code is valid or is within use/time limits.</li> <li>2. Special dealer access code is required for some system programming.</li> <li>3. Check that code used has sufficient authority to perform the item requested.</li> </ol>
	Customer cannot remember access code(s).	<ol style="list-style-type: none"> <li>1. Check your records or downloader database to see if you have the customer's access code(s) on file.</li> <li>2. If downloading software is available, read the panel access code(s) using the downloader.</li> </ol>
	Installer cannot remember install code.	<ol style="list-style-type: none"> <li>1. Check your records or downloader database to see if you have the install code on file.</li> <li>2. If downloading software is available, read the panel access code(s) using the downloader.</li> <li>3. If the panel has no access to downloading, clear memory (to defaults) and reprogram the panel locally.</li> </ol> <p><b>Note</b> Dealer access codes are not erased by clearing memory.</p>
	Access code stops working.	<ol style="list-style-type: none"> <li>1. Check for valid access code or that code use/time limits have not expired.</li> <li>2. Check for proper partition/area and code selection.</li> </ol>
<b>Duress Code</b>		
	Optional duress code is not working.	Check for valid code. (See List Access Codes feature.)
<b>Arming/Disarming</b>		
	System won't arm.	<ol style="list-style-type: none"> <li>1. If arming to Perimeter/Home, make sure all monitored perimeter doors and windows are closed or bypassed.</li> <li>2. If arming to Full/Away, make sure all perimeter <i>and interior</i> zone sensors are closed or bypassed.</li> <li>3. Check system status (press 1 + 9) for an indication of the problem.</li> </ol>
	System won't disarm.	<ol style="list-style-type: none"> <li>1. Check for proper access code.</li> <li>2. Check the access code authority setting.</li> </ol>
<b>Batteries</b>		
	Main battery and/or main battery failure is indicated.	Check the panel backup battery(s) and connections and replace if necessary. Also, refer to the Panel - Power LED section in this table.
	Zone [zone #] low battery is indicated.	Replace the indicated sensor battery.
<b>Bypassing</b>		
	<b>Note</b> Fire zones cannot be bypassed.	
	Fail and/or Invalid is indicated when you attempt to bypass a zone.	Zone may already be bypassed, or you are trying to bypass a 24-hour zone that cannot be bypassed.
	System won't automatically unypass closed zones.	Check that the Unbypassing feature is enabled in programming.

Feature	Problem	Solution
<b>Bypassing (continued)</b>		
	System only allows a certain number of zones to be bypassed.	Check Bypassing Limit feature programming for desired number.
<b>Central Station Reporting</b>		
	Central station is not receiving reports from panel.	<ol style="list-style-type: none"> <li>1. Perform a phone test. If phone test fails, follow the remaining steps</li> <li>2. Check that the DB-8 Cord is plugged into the panel phone jack and into the RJ-31X/CA-38A jack.</li> <li>3. Check for proper RJ-31X/CA-38A jack to phone line wiring.</li> <li>4. Verify with the central station operator that the correct receiver line phone number is programmed into the panel. Reprogram the phone number and retest if necessary.</li> <li>5. Verify that the correct phone reporting format is being used.</li> <li>6. Verify account number settings for each partition/area and for system.</li> <li>7. Replace faulty RJ-31X/CA-38A jack.</li> <li>8. Replace faulty DB-8 cord.</li> <li>9. Check that the premises phone line is working.</li> </ol>
<b>Devices</b>		
	(See X-10 Modules, Hardwire Outputs, or 4 Relay Output Module).	
<b>Dual Phone Line Module</b>		
	Module bus status LED stays off.	<ol style="list-style-type: none"> <li>1. Check module and panel power (Green LEDs on).</li> <li>2. Check SuperBus wiring and connections.</li> <li>3. Check that the module is programmed (added/learned) into panel memory. Add the module if necessary.</li> </ol>
	Module bus status LED stays on.	<ol style="list-style-type: none"> <li>1. Reinitialize panel and module by turning panel power off and back on.</li> <li>2. Module circuit failure. Replace the module.</li> </ol>
	Module bus status LED blinks, but phones don't work.	<ol style="list-style-type: none"> <li>1. Check phone wiring and connections.</li> <li>2. Check that the module is programmed (added/learned) into panel memory. Add the module if necessary.</li> </ol>
	Module phone line status LED is on.	Check for phone line failure or phone wiring and connections for that line.
	Phones connected to module work intermittently.	<ol style="list-style-type: none"> <li>1. Check module and panel (Green LEDs on).</li> <li>2. Check Superbus wire routing and length. (Shielded cable may be required on very long or noisy wire runs.)</li> <li>3. Check panel/module programming.</li> </ol>
	Only one module phone line works.	Only 1 phone line module is allowed.
<b>False Alarm</b>		
	Alarm is being sent by mistake.	<p>Enter the access code immediately to cancel the alarm. This command aborts the alarm report if done within 5 seconds (alarm report delay time [xx012, xx013, or xx014]) after alarm activation (Dialer Abort feature must be on). The system will indicate <i>Report Canceled</i> and the report will not be sent to the monitoring station. If setting xx089 is set to on.</p> <p><b>Note</b> Some alarms such as Fire alarms will not be aborted.</p>

Feature	Problem	Solution
<b>Hardwire Alphanumeric Touchpad</b>		
	Touchpad displays <i>Touchpad Not Enrolled</i> and does not respond to buttons.	Enter panel programming mode by entering 8 + 0 and the install code at a working touchpad or from a telephone. Enter item number 48001 and enroll the new touchpad into panel memory. If no touchpads are enrolled into the panel's memory, remove then restore panel power. All touchpads will be enrolled.
	Touchpad displays ***** and does not respond to button presses.	Check for SuperBus miswiring.
	Touchpad appears "dead" (no display or response to buttons).	<ol style="list-style-type: none"> <li>1. Check that the wiring connector is plugged into the back of the touchpad and into the panel bus connector.</li> <li>2. Check SuperBus wiring for opens or shorts.</li> <li>3. Check panel power.</li> </ol>
<b>Hardwire Inputs</b>		
	No inputs detected.	<ol style="list-style-type: none"> <li>1. Check panel programming of all general purpose inputs/outputs.</li> <li>2. Check all input device wiring and connections.</li> </ol>
	One input is never detected.	<ol style="list-style-type: none"> <li>1. Check panel programming of general purpose input/output.</li> <li>2. Check input device operation.</li> <li>3. Check input device wiring and connections.</li> </ol>
	Wrong input is detected.	<ol style="list-style-type: none"> <li>1. Check panel input programming for input.</li> <li>2. Check input device wiring and connections.</li> </ol>
<b>Hardwire Outputs</b>		
	No outputs activate.	<ol style="list-style-type: none"> <li>1. Check panel/module programming.</li> <li>2. Check output wiring and connections.</li> <li>3. Check panel/module power (green LEDs on).</li> <li>4. If used, check the optional external supply powering the output devices.</li> </ol>
	One output never activates.	<ol style="list-style-type: none"> <li>1. Check panel/module programming for that output.</li> <li>2. Check output wiring and connections.</li> <li>3. Check that the output programmed trigger event actually occurs.</li> <li>4. Output relay may have failed or been overloaded. Reprogram to use a different (unused) output or replace the module.</li> </ol>
	Wrong output activates.	<ol style="list-style-type: none"> <li>1. Check panel output programming.</li> <li>2. Check output device wiring and connections.</li> </ol>
<b>Hardwire Sirens/Bells</b>		
	Exterior sirens are not producing alarm sounds.	<ol style="list-style-type: none"> <li>1. Check for 12 VDC between panel terminals 6 and 7 during alarm (partition/area 1).</li> <li>2. Check panel main power.</li> <li>3. Check for correct wiring at the siren and panel terminals.</li> <li>4. Check exterior siren output programming.</li> <li>5. Be sure that there is a siren output in each partition that is used.</li> </ol>
	Exterior sirens produce status sounds.	<ol style="list-style-type: none"> <li>1. Check for correct wiring at the siren and panel terminals.</li> <li>2. Check exterior siren output programming.</li> </ol>

Feature	Problem	Solution
<b>Hardwire Sirens/Bells (continued)</b>		
	Interior bells are not producing sounds.	<ol style="list-style-type: none"> <li>1. Check for 12 VDC between panel terminals 4 and 5 with bell activated (partition/area 1).</li> <li>2. Check panel main power.</li> <li>3. Check for correct wiring at the siren and panel terminals.</li> <li>4. Check interior bell programming.</li> <li>5. Be sure that there is an interior bell output programmed for each partition/area that is used.</li> </ol>
<b>Hardwire Speakers (Voice)</b>		
	Speakers are not producing sounds.	<ol style="list-style-type: none"> <li>1. Check for correct wiring (and opens or shorts) at the speaker and panel terminals.</li> <li>2. Check that required capacitor and end of line (EOL) resistor are installed at the speaker.</li> <li>3. Make sure that voice volume is correctly programmed.</li> <li>4. Speaker output is used for partition/area 1 only.</li> </ol>
	Speaker volume too high or low.	<ol style="list-style-type: none"> <li>1. Make sure that the voice volume is correctly programmed.</li> <li>2. Check for too many speakers or incorrect speaker impedance.</li> </ol>
<b>Hardwire Zones</b>		
	Panel does not respond to hardwire zone input.	<ol style="list-style-type: none"> <li>1. Check that zones are programmed into panel and add if missing.</li> <li>2. Make sure that zone is set to a restoral-required type or make sure that system is armed to active level before tripping sensor.</li> <li>3. If it is an optional 8 Input Module zone, check that the module bus status LED is blinking to show communication with panel.</li> <li>4. Check zone programming for proper partition/area setting.</li> </ol>
<b>Lights (See also X-10 Modules, Hardwire Outputs, or 4 Relay Output Module)</b>		
	Light fixture using X-10 Lamp Module does not work.	See X-10 Modules feature in this table.
<b>Panel</b>		
	Panel does not power up. Panel LED is off and alphanumeric touchpad display is dark.	<ol style="list-style-type: none"> <li>1. Check the AC circuit breaker to be sure the circuit is live.</li> <li>2. Check that the backup battery is installed correctly, the battery wires are connected, and the AC power transformer is plugged in.</li> <li>3. Check for proper panel and transformer wiring.</li> <li>4. Measure the incoming AC voltage at the panel terminals. The voltage should be about 24 VAC between panel terminals 1 and 2.</li> </ol>
	No incoming AC voltage at panel terminals 1 and 2.	<ol style="list-style-type: none"> <li>1. Check that AC power transformer is not wired into a switched circuit.</li> <li>2. Remove AC power from the transformer and disconnect the wires from the transformer and the panel.</li> <li>3. Check transformer to panel wire for short or open circuits.</li> <li>4. Connect the transformer and check for about 24 VAC at the transformer unconnected terminals. If zero (0) volts, reset the built-in transformer circuit breaker (if it has one) or replace the transformer.</li> </ol>

Feature	Problem	Solution
<b>Panel (continued)</b>		
	Panel power LED is on constantly, display indicates <i>Main Low Battery</i> or voice sounds <i>Main Low Battery</i> .	<ol style="list-style-type: none"> <li>1. Check that the panel backup battery is installed correctly, the battery wires are connected, and the AC power transformer is connected.</li> <li>2. Measure the incoming AC voltage at the panel terminals. It should read about 24 VAC at panel terminals 1 and 2.</li> <li>3. Remove the panel backup battery power by disconnecting the red (positive) battery wire.</li> <li>4. Check for 13.6 to 14.2 VDC battery charging voltage between panel terminal 3 (GND) and the disconnected red battery wire.</li> <li>5. Check fuse in the red battery wire.</li> <li>6. Check for 11.5 to 13.9 VDC battery voltage between the backup battery spade lugs. If the battery voltage is <i>not</i> within the recommended range, allow the battery time to charge or replace faulty battery.</li> </ol> <p><b>Note</b> When the panel is running a backup battery test, the reading at the connected battery can range from 11.4 to 13.7 VDC. The panel automatically runs a backup battery test once every 4 or 24 hours (programmed test interval) and at STIME.</p> <ol style="list-style-type: none"> <li>7. Restore the backup battery power by reconnecting the red wire from the battery.</li> </ol> <p><b>Note</b> While the AC power transformer is plugged in, the panel automatically charges the battery. While the battery is charging for the first time it is normal for the system to indicate <i>Main Low Battery</i>. This can take a number of hours depending on the initial battery charge. Once the battery reaches full charge as measured while in battery test, trouble indication will stop once cleared by pressing the * button. If the trouble condition persists after 24 hours, replace the backup battery.</p>
	Panel power LED quickly flashes once a second, and after pressing 1 + 9, the touchpad indicates <i>Main Power Failure</i> . (Panel continues to operate from backup battery.)	<ol style="list-style-type: none"> <li>1. Check the AC circuit breaker to be sure the circuit is live.</li> <li>2. Check for proper panel and transformer wiring.</li> <li>3. Check that the AC transformer is wired to a non-switched circuit.</li> <li>4. Check that the transformer is supplying AC to the panel. (Transformer internal breaker or fuse may be blown.)</li> </ol>
	Panel power LED blinks. (Panel power is on and receiving AC power).	<p>Panel internal failure is detected - service is required:</p> <ul style="list-style-type: none"> <li><input type="checkbox"/> 3 Blinks - Program memory checksum failure.</li> <li><input type="checkbox"/> 4 Blinks - Voice memory checksum failure.</li> <li><input type="checkbox"/> 5 Blinks - EVAC memory checksum failure.</li> <li><input type="checkbox"/> 7 Blinks - RAM failure.</li> </ul>
<b>Partitions/Areas</b>		
	Only partition/area one (1) functions.	<ol style="list-style-type: none"> <li>1. Check that other partitions/areas are enabled.</li> <li>2. Check that devices are correctly added (learned) into the other enabled partitions/areas.</li> </ol>
<b>Phones</b>		
	Loss of dial tone on premises phones after wiring the RJ-31X jack or connecting the DB-8 Cord.	<ol style="list-style-type: none"> <li>1. Wait 2 minutes and try again. The panel may be busy trying to report to the central station receiver.</li> <li>2. Check the RJ-31X jack wiring.</li> <li>3. Check the panel connection to the DB-8 cord.</li> <li>4. Replace the RJ-31X jack.</li> <li>5. Replace the DB-8 cord.</li> <li>6. Perform a phone test after troubleshooting the phone line.</li> </ol>
	Constant dial tone is preventing dial-out on premises phones.	Polarity-sensitive phones exist on the premises. Reverse the phone wires connected to the brown and gray wire terminals on the RJ-31X jack.
	Phone does not work.	Disconnect the panel DB-8 Cord from the RJ-31 jack. If the phone still doesn't work, the system is okay and the problem is in the wiring.

Feature	Problem	Solution
<b>Phones (continued)</b>		
	System does not respond to remote phone access.	Check that Remote Phone Enable panel feature (17086) is set to “on.”
	Noisy or “radio” sounds on phone when system answers.	<ol style="list-style-type: none"> <li>1. Check phone wire routing and connections.</li> <li>2. Check for good panel ground connection.</li> </ol>
<b>Printer or Automation Module</b>		
	Module bus status LED stays off.	<ol style="list-style-type: none"> <li>1. Check module and panel power (green LEDs on).</li> <li>2. Check SuperBus wiring and connections.</li> </ol>
	Module bus status LED stays on.	<ol style="list-style-type: none"> <li>1. Reinitialize panel and module by turning panel power off then on.</li> <li>2. Module circuit failure. Replace the module.</li> </ol>
	Module bus status LED blinks, but no interface operation.	<ol style="list-style-type: none"> <li>1. Panel and module are communicating correctly via the SuperBus.</li> <li>2. Check that device is learned into panel memory.</li> <li>3. Check panel/module programming.</li> <li>4. Check module and device cables and connections.</li> </ol>
<b>RF Transceiver Module (see also, Hardwire Outputs, Wireless Sensors, and Panel)</b>		
	Module bus status LED stays off.	<ol style="list-style-type: none"> <li>1. Check module and panel power (green LEDs on).</li> <li>2. Check SuperBus wiring and connections.</li> <li>3. Check for proper panel/module power-up initialization.</li> </ol>
	Module bus status LED stays on.	<ol style="list-style-type: none"> <li>1. Reinitialize panel and module by turning panel power off and on.</li> <li>2. Module circuit failure. Replace the module.</li> </ol>
	Module bus status LED blinks, but limited or no module wireless operation.	<ol style="list-style-type: none"> <li>1. Panel and module are communicating correctly via the SuperBus.</li> <li>2. Check that transceiver is learned into panel memory.</li> <li>3. Check panel/module programming.</li> <li>4. Check antenna and ground connections.</li> <li>5. Check for too close of proximity to metal obstructions such as ducting or AC wiring.</li> </ol>
	Limited wireless signal range.	<ol style="list-style-type: none"> <li>1. Check Commercial RF Transceiver Module antenna and ground connections. (Never bend or cut wireless radio antennas.)</li> <li>2. Check for too close a proximity to metal obstructions such as ducting or large appliances.</li> <li>3. Check/change transmitting device orientation to module.</li> </ol>
<b>Schedules</b>		
	Wrong clock time, date, or day indication.	<ol style="list-style-type: none"> <li>1. Check panel clock/calendar programming.</li> <li>2. Check panel day of week programming.</li> </ol>
	Schedules don’t repeat.	<ol style="list-style-type: none"> <li>1. Check panel schedules programming.</li> <li>2. Check if system clock/calendar has been changed since schedules were programmed.</li> </ol>
<b>Sensors/Zones (see also wireless smoke sensors)</b>		
	<i>Zone # Tamper</i> is indicated.	Replace the zone sensor cover if it is off. Trip and reset the sensor.

Feature	Problem	Solution
<b>Sensors/Zones (see also wireless smoke sensors) (continued)</b>		
	<i>Zone # Supervisory Failure</i> is indicated.	The zone/sensor is not communicating with the panel.
	<i>Zone # Trouble Low Battery</i> is indicated.	Replace the indicated zone sensor battery.
<b>Tamper Indications</b>		
		<ol style="list-style-type: none"> <li>1. Check that wireless sensor covers are in place.</li> <li>2. Check that surface tampered wireless PIRs, Smoke, and Sound sensors are securely mounted.</li> <li>3. Check that hardwired sensor loop end of line (EOL) resistors are installed.</li> <li>4. Check for hardwire sensor loop shorts or opens.</li> <li>5. If panel door is tampered, check that the panel cover is closed.</li> <li>6. If phone jack is tampered, check that phone line cords are plugged in.</li> <li>7. Check that Commercial RF Transceiver antennas are not bent, cut, or missing and that antenna and ground connections are tight.</li> <li>8. Check for multiple incorrect access code entries from touchpad or phone.</li> </ol>
<b>Trouble Beeps (see also Panel)</b>		
		Check system status for an indication of the problem. Troubles must be individually acknowledged to silence the beeps.
<b>Wireless Sensors (also see RF Transceiver Module)</b>		
	The panel does not respond to sensor activity. There are no alarm, chime, or sensor test sounds.	<ol style="list-style-type: none"> <li>1. Check that the wireless sensor battery is installed.</li> <li>2. Check the sensor battery for low voltage. Replace batteries if necessary.</li> <li>3. Use an RF Sniffer tool (60-401) to verify that the sensor is transmitting.</li> <li>4. Check that the sensor is programmed (added/learned) into panel memory. Add the sensor if necessary.</li> <li>5. Check partition/area setting.</li> <li>6. Verify that both RF Transceiver module antennas are installed and that the connections are tight.</li> </ol>
	The panel responds intermittently to wireless sensor signals.	<ol style="list-style-type: none"> <li>1. Rotate the sensor position from 90 to 180 degrees.</li> <li>2. Mount the sensor in a different location.</li> <li>3. Verify that both RF Transceiver Module antennas are installed and connections tight.</li> </ol>
<b>Wireless Smoke Sensor (see also RF Transceiver Module)</b>		
	Beeps once every minute.	Sensor batteries are low. Replace all of the smoke sensor batteries.
	<i>Zone # Partial Obscurity Trouble</i> is indicated.	Check for blocked dirty sensor screen and clean if necessary.
	<i>Zone # Trouble</i> is indicated.	Replace the zone/sensor cover, if it is off. Trip the sensor. Check for blocked dirty sensor screen and clean if necessary.
	<i>Zone # Supervisory Failure</i> is indicated.	The sensor is not communicating with the panel.
	<i>Zone # Trouble Low Battery</i> is indicated.	Replace the indicated sensor battery.
<b>Wireless Touchpads</b>		
	The panel does not respond to wireless touchpad commands.	<ol style="list-style-type: none"> <li>1. Operate touchpads from different locations to locate areas of intermittent operation.</li> <li>2. Check and/or replace wireless touchpad battery.</li> <li>3. Program or reprogram the touchpad(s) into the panel.</li> </ol>



Feature	Problem	Solution
<b>X-10 Lamp/Appliance Modules</b>		
	Lights or devices controlled by the X-10 Modules are not working.	<ol style="list-style-type: none"> <li>1. Check that the light or device is working and the power switch is on.</li> <li>2. Confirm light or device operation at working outlet.</li> <li>3. Check that the lights or devices are plugged into X-10 Modules and that the X-10 Modules are plugged into outlets that are not controlled by a switch. If necessary, relocate modules to non-switched outlets.</li> <li>4. Check that the HOUSE dial on the X-10 Modules match the house code programmed into the panel.</li> <li>5. Check for correct X-10 module unit settings and panel programming.</li> </ol>
<b>Zones, Loops</b>		
	(See Hardwire Inputs, Sensors.)	

## Appendix A: System Configuration Worksheets

Use Table A1 to determine maximum and standby current draw based on the devices connected to the panel.

Customer Name \_\_\_\_\_

Address \_\_\_\_\_

City \_\_\_\_\_ County \_\_\_\_\_ State \_\_\_\_\_

Zip \_\_\_\_\_ Phone (\_\_\_\_) \_\_\_\_\_

**Table A1: System Hardwire Devices**

Part No.	Description	Qty.	Standby Current Draw	Standby Current Subtotal	Maximum Current Draw	Maximum Current Subtotal
<b>Hardwire Sensors/Detectors</b>						
13-082	PIR Motion Detector		10 mA		10 mA	
13-443	2-Wire Smoke Sensor		100 uA		N/A	
13-444	2-Wire Smoke/Heat Sensor		100 uA		N/A	
	Fire Pull Station		N/A		N/A	
<b>Hardwire Sirens/Speakers</b>						
13-046	Hardwire Exterior Siren		N/A		145 mA	
13-060	8 Ohm, 15W Speaker		N/A		N/A	
<b>SuperBus 2000 Touchpads and Modules (31 Devices per Bus Header)</b>						
60-768	SuperBus 2000 Dual Phone Line Module		20 mA		60 mA	
60-783 (plastic) 60-854 (metal)	SuperBus 2000 Printer Module		30 mA		35 mA	
60-783-02	SuperBus 2000 RS 232 Automation Module*		35 mA		35 mA	
60-803-01	SuperBus 2000 2x20 LCD Alphanumeric Touchpad		75 mA		120 mA	
60-804-01	SuperBus 2000 2x20 VFD Alphanumeric Touchpad		75 mA		120 mA	
60-810-04	SuperBus 2000 2x20 VFD Fire Alphanumeric Touchpad		75 mA		120 mA	
60-821-95 (plastic) 60-856-95 (metal)	SuperBus 2000 RF Commercial Transceiver Module		50 mA		50 mA	
60-774	SuperBus 2000 8Z Hardwire Input Module		18 mA		35 mA	
60-770	SuperBus 2000 4-Relay Output Module		25 mA		180 mA	
<b>SnapCards (2 per panel)</b>						
60-756	4 Input/2 Output SnapCard		10 mA + 2.5 mA per zone used + 7 mA per smoke loop used + 34 mA per relay used		185 mA	
60-757	8Z Hardwire Input SnapCard		10 mA + 2.5 mA per zone used + 7 mA per smoke loop used		230 mA	
60-758	4 Output SnapCard		6 mA + 34 mA per relay used		130 mA	
Total Standby Current Draw (must not exceed 150 mA with 1 battery, 850 mA with 2 batteries, or 1.5A with 3 batteries for UL systems). Total Maximum Current Draw (must not exceed 5A).						

\* Not investigated by UL.

## Determining Maximum Panel Wire Length

### Example:

Using 22 gauge wire to connect the following devices on one wire run (length of cable):

Device Current Draw (see note)

- 1- Hardwire 2-Line Alpha Touchpad = 120 mA
- 1- RF Transceiver Module = 50 mA
- 1-8Z Hardwire Input Module = 35 mA

Total Device Current Draw = 205 mA

Find the total device current draw in the table and match the wire type used. In this example, the maximum recommended wire length is about 154 feet. For longer lengths, use a larger gauge wire.

### Note

For self- or remotely-powered devices, the maximum recommended wire length is 4,000 feet using 18 gauge or larger wire.

**Table A2: Max. Wire Length Recommendations\***

Total Device Current Draw (mA)	22 Gauge (AWG)	18 Gauge (AWG)	16 Gauge (AWG)	14 Gauge (AWG)
100	616	1,562	2,486	3,936
200	308	782	1,244	1,968
300	206	522	830	1314
400	154	392	622	982
500	124	314	500	792
600	104	262	416	653
700	88	224	356	564
800	78	196	312	492
900	70	174	278	438
1000	61	156	250	394
1100	56	142	226	358
1200	54	130	208	330
1300	48	120	192	304
1400	44	112	178	282
1500	42	104	166	264
1600	40	98	156	246
1700	36	92	146	232
1800	34	88	138	216
1900	32	82	132	208
2000	30	78	126	198
2100	29	74	120	188
2200	28	72	114	180
2300	27	68	108	172
2400	26	66	104	164
2500	25	64	100	158

**Table A2: Max. Wire Length Recommendations\***

Total Device Current Draw (mA)	22 Gauge (AWG)	18 Gauge (AWG)	16 Gauge (AWG)	14 Gauge (AWG)
2600	24	60	96	152
2700	23	58	92	146
2800	22	56	90	140
2900	21	54	86	136
3000	20	52	84	132

\*Two volt maximum loop voltage drop.

## Other System Devices

**Table A3: Wireless Sensors**

Part No.	Description	Qty.
60-348	Handheld Wireless Touchpad	
60-362	Learn Mode Door/Window Sensor	
60-409	Learn Mode Recessed Door/Window Sensor	
60-452	Learn Mode Pendant Panic Sensor	
60-453	Wall-Mount Wireless Touchpad	
60-457	Dual Button Panic Sensor	
60-458	Single Button Panic Sensor	
60-460	Rate-of-Rise Heat Sensor	
60-461	Learn Mode Shock Sensor	
60-462	Learn Mode Glass Guard Sensor	
60-499	Learn Mode Slim Line Door/Window Sensor	
60-504	Learn Mode Freeze Sensor	
60-506-319.5	Learn Mode Smoke Sensor	
60-838	Learn Mode Smoke Sensor (System Sensor) 2100ARFT	
60-848-95	Learn Mode Smoke Sensor (ESL) 560 Series	
60-849-95	Learn Mode Smoke Sensor (ESL) 570 Series	
60-511	Learn Model DS924i PIR Motion Sensor	
60-578	Water-Resistant Panic Sensor	
60-582	Learn Mode Sound Sensor (IntelliSense)	
60-641	Learn Mode Long Life Door/Window Sensor	
60-688	Learn Mode Micro Door/Window Sensor	
60-741	Learn Mode Recessed Micro Door/Window Sensor	

**Table A4: X-10 Module Line Carrier Devices**

Part No.	Description	Qty.
13-399	X-10 Universal Module	
13-402	X-10 Appliance Module	
13-403	X-10 Lamp Module	



**Partition/Area Descriptions**

Use Table A7 to write in information about each partition or area.

**Table A7: Partition/Area Numbers and Descriptions**

Partition/ Area No.	Description/Location [Display Text]
1	
2	
3	
4	
5	
6	
7	
8	



**Zone and Sensor Information**

Use Table A9 to record information about zones and sensors.

**Table A9: Zone and Sensor Assignments**

Zone Number	Partition Number	Zone Type	Zone/Sensor Type (circle one)	Module Bus ID Number	Module Input Number	Attributes (NO, NC, Floor No., etc.)	Zone/Sensor Text
01			HW/RF				
02			HW/RF				
03			HW/RF				
04			HW/RF				
05			HW/RF				
06			HW/RF				
07			HW/RF				
08			HW/RF				
09			HW/RF				
10			HW/RF				
11			HW/RF				
12			HW/RF				
13			HW/RF				
14			HW/RF				
15			HW/RF				
16			HW/RF				
17			HW/RF				
18			HW/RF				
19			HW/RF				
20			HW/RF				
21			HW/RF				
22			HW/RF				
23			HW/RF				
24			HW/RF				
25			HW/RF				
26			HW/RF				
27			HW/RF				
28			HW/RF				
29			HW/RF				
30			HW/RF				
31			HW/RF				
32			HW/RF				
33			HW/RF				
34			HW/RF				
35			HW/RF				
36			HW/RF				

**Table A9: Zone and Sensor Assignments (Continued)**

Zone Number	Partition Number	Zone Type	Zone/Sensor Type (circle one)	Module Bus ID Number	Module Input Number	Attributes (NO, NC, Floor No., etc.)	Zone/Sensor Text
37			HW/RF				
38			HW/RF				
39			HW/RF				
40			HW/RF				
41			HW/RF				
42			HW/RF				
43			HW/RF				
44			HW/RF				
45			HW/RF				
46			HW/RF				
47			HW/RF				
48			HW/RF				
49			HW/RF				
50			HW/RF				
51			HW/RF				
52			HW/RF				
53			HW/RF				
54			HW/RF				
55			HW/RF				
56			HW/RF				
57			HW/RF				
58			HW/RF				
59			HW/RF				
60			HW/RF				
61			HW/RF				
62			HW/RF				
63			HW/RF				
64			HW/RF				
65			HW/RF				
66			HW/RF				
67			HW/RF				
68			HW/RF				
69			HW/RF				
70			HW/RF				
71			HW/RF				
72			HW/RF				
73			HW/RF				
74			HW/RF				
75			HW/RF				



**Table A9: Zone and Sensor Assignments (Continued)**

Zone Number	Partition Number	Zone Type	Zone/Sensor Type (circle one)	Module Bus ID Number	Module Input Number	Attributes (N0, NC, Floor No., etc.)	Zone/Sensor Text
76			HW/RF				
77			HW/RF				
78			HW/RF				
79			HW/RF				
80			HW/RF				
81			HW/RF				
82			HW/RF				
83			HW/RF				
84			HW/RF				
85			HW/RF				
86			HW/RF				
87			HW/RF				
88			HW/RF				
89			HW/RF				
90			HW/RF				
91			HW/RF				
92			HW/RF				
93			HW/RF				
94			HW/RF				
95			HW/RF				
96			HW/RF				
97			HW/RF				
98			HW/RF				
99			HW/RF				
100			HW/RF				
101			HW/RF				
102			HW/RF				
103			HW/RF				
104			HW/RF				
105			HW/RF				
106			HW/RF				
107			HW/RF				
108			HW/RF				
109			HW/RF				
110			HW/RF				
111			HW/RF				
112			HW/RF				
113			HW/RF				
114			HW/RF				

**Table A9: Zone and Sensor Assignments (Continued)**

Zone Number	Partition Number	Zone Type	Zone/Sensor Type (circle one)	Module Bus ID Number	Module Input Number	Attributes (NO, NC, Floor No., etc.)	Zone/Sensor Text
115			HW/RF				
116			HW/RF				
117			HW/RF				
118			HW/RF				
119			HW/RF				
120			HW/RF				
121			HW/RF				
122			HW/RF				
123			HW/RF				
124			HW/RF				
125			HW/RF				
126							
127							
128							
129							
130							
131							
132							
133							
134							
135							
136							
137							
138							
139							
140							
141							
142							
143							
144							
145							
146							
147							
148							
149							
150							
151							
152							
153							

**Table A9: Zone and Sensor Assignments (Continued)**

Zone Number	Partition Number	Zone Type	Zone/Sensor Type (circle one)	Module Bus ID Number	Module Input Number	Attributes (N0, NC, Floor No., etc.)	Zone/Sensor Text
154							
155							
156							
157							
158							
159							
160							
161							
162							
163							
164							
165							
166							
167							
168							
169							
170							
171							
172							
173							
174							
175							
176							
177							
178							
179							
180							
181							
182							
183							
184							
185							
186							
187							
188							
189							
190							
191							
192							

**Table A9: Zone and Sensor Assignments (Continued)**

Zone Number	Partition Number	Zone Type	Zone/Sensor Type (circle one)	Module Bus ID Number	Module Input Number	Attributes (NO, NC, Floor No., etc.)	Zone/Sensor Text
193							
194							
195							
196							
197							
198							
199							
200							
201							
202							
203							
204							
205							
206							
207							
208							
209							
210							
211							
212							
213							
214							
215							
216							
217							
218							
219							
220							
221							
222							
223							
224							
225							
226							
227							
228							
229							
230							
231							







## Item Numbers Index and Record

Use Table A14 to document settings. Items are in numerical order.

**Table A14: Item Numbers Index and Record**

Item Number	Setting Reference and Default	Setting
Installer Programming—8 + 0 + Installer/Dealer CODE		
01001-08001	LTIME Sound Time (p. 17) 12:00	1 _____, 3 _____, 5 _____, 7 _____, 2 _____, 4 _____, 6 _____, 8 _____
01002-08002	Siren Sound Time (p. 17) 16 min.	1 _____, 3 _____, 5 _____, 7 _____, 2 _____, 4 _____, 6 _____, 8 _____
01003-08003	Entry Delay (p. 22) 32 sec	1 _____, 3 _____, 5 _____, 7 _____, 2 _____, 4 _____, 6 _____, 8 _____
01004-08004	Exit Delay (p. 22) 32 sec	1 _____, 3 _____, 5 _____, 7 _____, 2 _____, 4 _____, 6 _____, 8 _____
01005-08005	Extended Delay (p. 22) 2 min.	1 _____, 3 _____, 5 _____, 7 _____, 2 _____, 4 _____, 6 _____, 8 _____
01006-08006	Fast Beep Duration (p. 22) 10 sec	1 _____, 3 _____, 5 _____, 7 _____, 2 _____, 4 _____, 6 _____, 8 _____
01007-08007	Scheduled Arming Period (p. 21) 10 min.	1 _____, 3 _____, 5 _____, 7 _____, 2 _____, 4 _____, 6 _____, 8 _____
01008-08008	Scheduled Arming Extension (p. 21) 30 min.	1 _____, 3 _____, 5 _____, 7 _____, 2 _____, 4 _____, 6 _____, 8 _____
01009-08009	No Activity Tripped After (p. 18) 0 (Not Active)	1 _____, 3 _____, 5 _____, 7 _____, 2 _____, 4 _____, 6 _____, 8 _____
01010-08010	No Activity Report Delay (p. 18) 5 min.	1 _____, 3 _____, 5 _____, 7 _____, 2 _____, 4 _____, 6 _____, 8 _____
01011-08011	Zone Test Time Out (p. 23) 30 min.	1 _____, 3 _____, 5 _____, 7 _____, 2 _____, 4 _____, 6 _____, 8 _____
01012-08012	Panic Report Delay (p. 19) 5 sec	1 _____, 3 _____, 5 _____, 7 _____, 2 _____, 4 _____, 6 _____, 8 _____
01013-08013	Alarm Report Delay (p. 19) 5 sec	1 _____, 3 _____, 5 _____, 7 _____, 2 _____, 4 _____, 6 _____, 8 _____
01014-08014	Fire Report Delay (p. 20) 0 min.	1 _____, 3 _____, 5 _____, 7 _____, 2 _____, 4 _____, 6 _____, 8 _____
01015-08015	Suspicion Alarm Delay (p. 18) 5 min.	1 _____, 3 _____, 5 _____, 7 _____, 2 _____, 4 _____, 6 _____, 8 _____
01017-08017	Bypass Limit (p. 21) 250 (all)	1 _____, 3 _____, 5 _____, 7 _____, 2 _____, 4 _____, 6 _____, 8 _____
01018-08018	Activity Fault Threshold 1 (p. 20) 10	1 _____, 3 _____, 5 _____, 7 _____, 2 _____, 4 _____, 6 _____, 8 _____
01019-08019	Activity Fault Threshold 2 (p. 20) 30	1 _____, 3 _____, 5 _____, 7 _____, 2 _____, 4 _____, 6 _____, 8 _____
01020-08020	Activity Fault Threshold 3 (p. 20) 50	1 _____, 3 _____, 5 _____, 7 _____, 2 _____, 4 _____, 6 _____, 8 _____
01021-08021	Swing Count (Auto Bypass Trips) (p. 21) 3	1 _____, 3 _____, 5 _____, 7 _____, 2 _____, 4 _____, 6 _____, 8 _____
01022-08022	X-10 House Code 1 (p. 18) default is parti- tion/area number	1 _____, 3 _____, 5 _____, 7 _____, 2 _____, 4 _____, 6 _____, 8 _____
01023-08023	X-10 House Code 2 (p. 18) default is parti- tion/area number + 8	1 _____, 3 _____, 5 _____, 7 _____, 2 _____, 4 _____, 6 _____, 8 _____
01025-08025	Enable Level 2 Arming (p. 20) On	1 _____, 3 _____, 5 _____, 7 _____, 2 _____, 4 _____, 6 _____, 8 _____
01026-08026	Enable Level 3 Arming (p. 20) On	1 _____, 3 _____, 5 _____, 7 _____, 2 _____, 4 _____, 6 _____, 8 _____



Table A14: Item Numbers Index and Record (Continued)

Item Number	Setting Reference and Default	Setting
01027-08027	Enable Level 4 Arming (p. 20) On	1 _____, 3 _____, 5 _____, 7 _____, 2 _____, 4 _____, 6 _____, 8 _____
01028-08028	Enable Level 5 Arming (p. 20) On	1 _____, 3 _____, 5 _____, 7 _____, 2 _____, 4 _____, 6 _____, 8 _____
01049-08049	Non X-10 Output 1 (p. 19) None	1 _____, 3 _____, 5 _____, 7 _____, 2 _____, 4 _____, 6 _____, 8 _____
01050-08050	Non X-10 Output 2 (p. 19) None	1 _____, 3 _____, 5 _____, 7 _____, 2 _____, 4 _____, 6 _____, 8 _____
01051-08051	Non X-10 Output 3 (p. 19) None	1 _____, 3 _____, 5 _____, 7 _____, 2 _____, 4 _____, 6 _____, 8 _____
01052-08052	Non X-10 Output 4 (p. 19) None	1 _____, 3 _____, 5 _____, 7 _____, 2 _____, 4 _____, 6 _____, 8 _____
01053-08053	Non X-10 Output 5 (p. 19) None	1 _____, 3 _____, 5 _____, 7 _____, 2 _____, 4 _____, 6 _____, 8 _____
01054-08054	Non X-10 Output 6 (p. 19) None	1 _____, 3 _____, 5 _____, 7 _____, 2 _____, 4 _____, 6 _____, 8 _____
01055-08055	Non X-10 Output 7 (p. 19) None	1 _____, 3 _____, 5 _____, 7 _____, 2 _____, 4 _____, 6 _____, 8 _____
01056-08056	Non X-10 Output 8 (p. 19) None	1 _____, 3 _____, 5 _____, 7 _____, 2 _____, 4 _____, 6 _____, 8 _____
01057-08057	Unlock Button Action (p. 23) 4 (arm to level 1)	1 _____, 3 _____, 5 _____, 7 _____, 2 _____, 4 _____, 6 _____, 8 _____
01058-08058	Lock Button Action (p. 23) 9 (arm to closed level)	1 _____, 3 _____, 5 _____, 7 _____, 2 _____, 4 _____, 6 _____, 8 _____
01059-08059	Lights Button Action (p. 23) 15 (toggle all lights)	1 _____, 3 _____, 5 _____, 7 _____, 2 _____, 4 _____, 6 _____, 8 _____
01060-08060	Star Button Action (p. 23) 12 (incremental arming)	1 _____, 3 _____, 5 _____, 7 _____, 2 _____, 4 _____, 6 _____, 8 _____
01061-08061	Lights/Star Button Combination Action (p. 23) 3 (auxiliary panic)	1 _____, 3 _____, 5 _____, 7 _____, 2 _____, 4 _____, 6 _____, 8 _____
01063-08063	Direct Arm Level—3 Action (p. 23) 6 (arm to level 3)	1 _____, 3 _____, 5 _____, 7 _____, 2 _____, 4 _____, 6 _____, 8 _____
01064-08064	Direct Arm Level—1 Action (p. 23) 5 (arm to level 2)	1 _____, 3 _____, 5 _____, 7 _____, 2 _____, 4 _____, 6 _____, 8 _____
01065-08065	Lock/Star Button Combination (p. 23) 16 (do nothing)	1 _____, 3 _____, 5 _____, 7 _____, 2 _____, 4 _____, 6 _____, 8 _____
01066-08066	Disarm/Lights Button Combination (p. 23) 16 (do nothing)	1 _____, 3 _____, 5 _____, 7 _____, 2 _____, 4 _____, 6 _____, 8 _____
01068--08068	Partition/Area Enable (p. 16) Partition 1 On, Partitions 2–8 Off	1 _____, 3 _____, 5 _____, 7 _____, 2 _____, 4 _____, 6 _____, 8 _____
01069-08069	Light Access Code Enable (p. 19) Off	1 _____, 3 _____, 5 _____, 7 _____, 2 _____, 4 _____, 6 _____, 8 _____
01070-08070	Device Access Code Enable (p. 19) Off	1 _____, 3 _____, 5 _____, 7 _____, 2 _____, 4 _____, 6 _____, 8 _____
01071-08071	Latchkey Access Code Enable (p. 19) Off	1 _____, 3 _____, 5 _____, 7 _____, 2 _____, 4 _____, 6 _____, 8 _____
01076-08076	Keypad Tamper (p. 18) Off	1 _____, 3 _____, 5 _____, 7 _____, 2 _____, 4 _____, 6 _____, 8 _____
01077-08077	Second Intrusion Causes Report (p. 20) Off	1 _____, 3 _____, 5 _____, 7 _____, 2 _____, 4 _____, 6 _____, 8 _____
01078-08078	Generate Alarm for Suspicion Trips (p. 18) On	1 _____, 3 _____, 5 _____, 7 _____, 2 _____, 4 _____, 6 _____, 8 _____

**Table A14: Item Numbers Index and Record (Continued)**

Item Number	Setting Reference and Default	Setting
01079-08079	Zone Tamper Alarm Enable (p. 17) Off	1 _____, 3 _____, 5 _____, 7 _____, 2 _____, 4 _____, 6 _____, 8 _____
01080-08080	First Trip Local Second Trip Report (p. 18) Off	1 _____, 3 _____, 5 _____, 7 _____, 2 _____, 4 _____, 6 _____, 8 _____
01083-08083	Fire Tamper Response (p. 17) Off	1 _____, 3 _____, 5 _____, 7 _____, 2 _____, 4 _____, 6 _____, 8 _____
01084-08084	Auxiliary/Medical Assignment (p. 23) On (auxiliary alarm)	1 _____, 3 _____, 5 _____, 7 _____, 2 _____, 4 _____, 6 _____, 8 _____
01085-08085	Enable Police Panic Keys (p. 23) On	1 _____, 3 _____, 5 _____, 7 _____, 2 _____, 4 _____, 6 _____, 8 _____
01086-08086	Auxiliary Medical Panic Keys (p. 23) On	1 _____, 3 _____, 5 _____, 7 _____, 2 _____, 4 _____, 6 _____, 8 _____
01087-08087	Enable Fire Panic Keys (p. 23) On	1 _____, 3 _____, 5 _____, 7 _____, 2 _____, 4 _____, 6 _____, 8 _____
01088-08088	Report Partition/Area Events (p. 19) On	1 _____, 3 _____, 5 _____, 7 _____, 2 _____, 4 _____, 6 _____, 8 _____
01089-08089	Cancel Event Cancels Report (p. 19) On	1 _____, 3 _____, 5 _____, 7 _____, 2 _____, 4 _____, 6 _____, 8 _____
01090-08090	Second Fire Alarm Ends Reporting Delay (p. 20) On	1 _____, 3 _____, 5 _____, 7 _____, 2 _____, 4 _____, 6 _____, 8 _____
01091-08091	Print Partition/Area Events (p. 19) On	1 _____, 3 _____, 5 _____, 7 _____, 2 _____, 4 _____, 6 _____, 8 _____
01092-08092	Auto Forced Arming (p. 21) On	1 _____, 3 _____, 5 _____, 7 _____, 2 _____, 4 _____, 6 _____, 8 _____
01093-08093	Quick Arm (p. 21) On	1 _____, 3 _____, 5 _____, 7 _____, 2 _____, 4 _____, 6 _____, 8 _____
01094-08094	Enable Scheduled Arming (p. 20) On	1 _____, 3 _____, 5 _____, 7 _____, 2 _____, 4 _____, 6 _____, 8 _____
01095-08095	Swinger Bypass Enable (p. 21) On	1 _____, 3 _____, 5 _____, 7 _____, 2 _____, 4 _____, 6 _____, 8 _____
01096-08096	Automatic Unbypass Enable (p. 21) Off	1 _____, 3 _____, 5 _____, 7 _____, 2 _____, 4 _____, 6 _____, 8 _____
01097-08097	Exterior Siren Arming Verification (p. 21) Off	1 _____, 3 _____, 5 _____, 7 _____, 2 _____, 4 _____, 6 _____, 8 _____
01098-08098	Local Closing Report Verification (p. 20) Off	1 _____, 3 _____, 5 _____, 7 _____, 2 _____, 4 _____, 6 _____, 8 _____
01100-08100	Exit Beeps (p. 22) On	1 _____, 3 _____, 5 _____, 7 _____, 2 _____, 4 _____, 6 _____, 8 _____
01101-08101	Exit Delay Termination (p. 22) Off	1 _____, 3 _____, 5 _____, 7 _____, 2 _____, 4 _____, 6 _____, 8 _____
01102-08102	Exit Delay Reset (p. 22) Off	1 _____, 3 _____, 5 _____, 7 _____, 2 _____, 4 _____, 6 _____, 8 _____
01103-08103	Entry Delay Beeps (p. 22) Off	1 _____, 3 _____, 5 _____, 7 _____, 2 _____, 4 _____, 6 _____, 8 _____
01108-08108	Local Trouble Annunciation at LTime (p. 17) On	1 _____, 3 _____, 5 _____, 7 _____, 2 _____, 4 _____, 6 _____, 8 _____
01110-08110	Chime Text (p. 22) Off	1 _____, 3 _____, 5 _____, 7 _____, 2 _____, 4 _____, 6 _____, 8 _____
01111-08111	Close Chime (p. 23) Off	1 _____, 3 _____, 5 _____, 7 _____, 2 _____, 4 _____, 6 _____, 8 _____
01112-08112	All Restoral Reports (p. 20) Off	1 _____, 3 _____, 5 _____, 7 _____, 2 _____, 4 _____, 6 _____, 8 _____

Table A14: Item Numbers Index and Record (Continued)

Item Number	Setting Reference and Default	Setting
01113-08113	Exterior Siren Delay (p. 19) Off	1 _____, 3 _____, 5 _____, 7 _____, 2 _____, 4 _____, 6 _____, 8 _____
01116-08116	Account No. 1 (p. 16) 00000000	1 _____, 3 _____, 5 _____, 7 _____, 2 _____, 4 _____, 6 _____, 8 _____
01117-08117	Account No. 2 (p. 16) 00000000	1 _____, 3 _____, 5 _____, 7 _____, 2 _____, 4 _____, 6 _____, 8 _____
01118-08118	Default Keyfob/Schedule Arming Level (p. 20) 3	1 _____, 3 _____, 5 _____, 7 _____, 2 _____, 4 _____, 6 _____, 8 _____
01120-08120	Default Keyswitch Arming Level (p. 20) 3	1 _____, 3 _____, 5 _____, 7 _____, 2 _____, 4 _____, 6 _____, 8 _____
17001	System Date (p. 39) 1/1/00	
17002	System Time (p. 39) 12:00:00	
17003	System Day of Week (p. 39) Saturday	
17004	System Report Time (STIME) (p. 40) Random	
17006-17111 17118	General Input Response Times (p. 34) 32 sec	I/O 1 _____, I/O 3 _____, I/O 5 _____, I/O 7 _____ I/O 2 _____, I/O 4 _____, I/O 6 _____
17012-17017 17119-17120	Expansion Input Response Times (p. 34) 32 sec	1 _____, 3 _____, 5 _____, 7 _____, 2 _____, 4 _____, 6 _____, 8 _____
17018	Maximum Ring Cycle Time (p. 27) 67 ms	
17019	Minimum Ring Burst Duration (p. 28) 400 ms	
17020	Maximum Ring Burst Duration (p. 28) 2500 ms	
17021	Minimum Duration Between Ring Burst (p. 28) 0	
17022	Maximum Duration Between Ring Burst (p. 28) 0	
17023	Minimum Time Between Burst (p. 29) 2000 ms	
17024	Maximum Time Between Burst (p. 28) 4500 ms	
17025	Minimum Time Between Ring-Pause-Ring Calls (p. 30) 10 sec	
17026	Max Time Between Ring-Pause-Ring Calls (p. 31) 30 sec	
17027	On Hook Hang Up Time (p. 30) 4 sec	
17028	Local Phone Connect Time (p. 29) 2 sec	
17029	Local Phone Answer Time (p. 29) 8 sec	
17030	Time Between Phone Panic Keystrokes (p. 29) 2 sec	
17031	Minimum Tone Duration (p. 28) 30 ms	
17032	Minimum Duration Between Tones (p. 28) 50 ms	
17034	Interval Between Automatic Phone Test (p. 25) 1 day - Commercial, 7 days - Home Navigator	
17035	Touchpad Return Time (p. 16) 10 sec	
17036	AC Stable Time (p. 42) 8 sec	
17037	Low Battery Voltage (p. 41) 10.6V	

**Table A14: Item Numbers Index and Record (Continued)**

Item Number	Setting Reference and Default	Setting
17038	Battery Restored Voltage (p. 41) 11.6V	
17039	Start Shutdown Battery Voltage (p. 41) 9.4V	
17040	Cancel Shutdown Battery Voltage (p. 41) 10.4V	
17041	AC Report Delay (p. 41) 6 hrs	
17043	Percent Full History Buffer Reports (p. 40) 80 percent	
17044	Percent Full Report Buffer Reports (p. 40) 80 percent	
17046-17048	Sound Rhythms (p. 38) Medical alternate modulated, Police steady, Auxiliary fast modulated	Medical _____, Police _____, Auxiliary _____
17049-17050	RF Supervisory Times (p. 39) A 4 hrs, B 24 hrs	A _____, B _____
17052	Answer Phone after XX rings (p. 30) 12 Rings	
17053	Cancel Ring-Pause-Ring After XX Rings (p. 31) 3 rings	
17054	Minimum Valid Ring Cycles (p. 28) 2 cycles	
17055	Valid Ring Bursts (p. 28) 1 burst	
17056	Local Phone Control Sequence (p. 29) #*	
17057	Phone Device Override Sequence (p. 29) **##	
17058	Pager ID (p. 25) 0	
17060-17061	On Premises Pager IDs (p. 42) 0000000	1 _____, 2 _____
17062	System Strobe Light Type Amesco	
17063-17068	General Purpose I/O Direction (p. 34) 0 (input)	1 _____, 3 _____, 5 _____, 2 _____, 4 _____, 6 _____
17069	No Phone Line (p. 25) Off	
17070	Enable Daylight Savings Time Adjust (p. 41) On	
17072	Enable RF Jam Detect (p. 40) On	
17073	Automatic Battery Test Interval (p. 40) 4 hours	
17074	High Rise Installation (p. 40) Off	
17075	Long Range Radio (p. 40) Off	
17076	Commercial/Residential Option (p. 40) Home Navigator Off, Commercial On	
17078	Detect Receiver Failure (p. 39) On	
17079	Alarm Messages Played at High Volume (p. 38) On	
17080	Phone Police Panic Enable (p. 30) Off	
17081	Phone Aux/Med Panic Enable (p. 30) Off	
17082	Phone Fire Panic Enable (p. 30) Off	
17083	Evacuation Messages (p. 38) On	
17084	First Fire Alarm Disarm/Silence (p. 38) Commercial Fire On, Commercial Burglary Off	

**Table A14: Item Numbers Index and Record (Continued)**

Item Number	Setting Reference and Default	Setting
17085	Enable Local Phone Access in Partition/Area 1 (p. 29) Off	
17086	Enable Remote Phone Access (p. 30) On	
17087	Enable Remote Phone Ring Count (p. 30) On	
17088	Enable Remote Phone Ring-Pause-Ring (p. 30) On	
17089	Enable Remote Phone Override (p. 31) On	
17090	Enable Toll Saver (p. 30) On	
17092	Phone Off-Hook is Activity (p. 39) On	
17093	Global Account Reporting (p. 16) Off	
17094-17095	Enable Phone Line 1/2 DTMF Dialing (p. 24) On	1 _____, 2 _____
17096	Report System Events (p. 40) On	
17097	Print Line Feed after Carriage Return (p. 41) On	
17098	Allow Remote Phone Zone Test (p. 31) On	
17099	Print System Events (p. 41) On	
17100	Time Format (p. 39) Off (12 hr)	
17101	Buddy Dial Attempts (p. 25) 5	
17102	System Account Number 1 (p. 25) 00000000	
17103	System Account Number 2 (p. 25) 00000000	
17104	Evacuation Message Count (p. 38) 4 messages	
17105	Phone Line 1 Dialing Prefix (p. 24) None	
17106	Phone Line 2 Dialing Prefix (p. 24) None	
17107	Dealer Access Code (p. 24) None	
17108	Downloader Access Code (p. 24) 12345	
17109	Downloader Account Number (p. 42) 00000000	
17110	Latitude Adjustment (p. 42) 0 degrees	
17111	Time Fire Alarm is Silenced (p. 38) 30 sec	
17112	Output Delay Time (p. 34) 30 sec	
17113-17116	Activation Interval One-Shot Times (p. 34) A 4 sec, B 30 sec, C 180 sec, D 900 sec	A _____, B _____, C _____, D _____
17117	Zone Delay Time (p. 33) 10 sec	
17122	Downloader Callback (p. 39) Off	
17123	AC Frequency (p. 42) 60 Hz	
17124	Printer Supports Epson ESC/P Protocol (p. 41) On	
17125	Partition/Area Text Speech (p. 40) On	
17126	Unsilence Alarm (p. 38) Off	
17127	Areas (p. 16) Off	
17128	Annunciate Earliest Fire Alarm (p. 38) Off	

**Table A14: Item Numbers Index and Record (Continued)**

Item Number	Setting Reference and Default	Setting
19001-24001	Reporting Number Enable (p. 25) Off	19001 _____, 20001 _____, 21001 _____, 22001 _____, 23001 _____, 24001 _____
19002-24002	Phone Numbers (p. 26) None	19002 _____, 20002 _____, 21002 _____, 22002 _____, 23002 _____, 24002 _____
19003-24003	Number of Attempts (p. 26) 5	19003 _____, 20003 _____, 21003 _____, 22003 _____, 23003 _____, 24003 _____
19004-24004	Communication Format (p. 26) 0 (Contact ID)	19004 _____, 20004 _____, 21004 _____, 22004 _____, 23004 _____, 24004 _____
19005-24005	Report Panic Special (p. 26) Off	19005 _____, 20005 _____, 21005 _____, 22005 _____, 23005 _____, 24005 _____
25001-40001	Pager Phone Number Enable (p. 26) Off	25001 _____, 26001 _____, 27001 _____, 28001 _____, 29001 _____, 30001 _____, 31001 _____, 32001 _____, 33001 _____, 34001 _____, 35001 _____, 36001 _____, 37001 _____, 38001 _____, 39001 _____, 40001 _____
25002-40002	Pager Phone Number (p. 26) None	25002 _____, 26002 _____, 27002 _____, 28002 _____, 29002 _____, 30002 _____, 31002 _____, 32002 _____, 33002 _____, 34002 _____, 35002 _____, 36002 _____, 37002 _____, 38002 _____, 39002 _____, 40002 _____
25003-40003	Number of Attempts (p. 27) 3	25003 _____, 26003 _____, 27003 _____, 28003 _____, 29003 _____, 30003 _____, 31003 _____, 32003 _____, 33003 _____, 34003 _____, 35003 _____, 36003 _____, 37003 _____, 38003 _____, 39003 _____, 40003 _____
25004-40004	Communication Format (p. 27) 1 (TAP at 1200 bps PSK)	25004 _____, 26004 _____, 27004 _____, 28004 _____, 29004 _____, 30004 _____, 31004 _____, 32004 _____, 33004 _____, 34004 _____, 35004 _____, 36004 _____, 37004 _____, 38004 _____, 39004 _____, 40004 _____
25005-40005	Communication Character Format (p. 27) 1 (7/E/1)	25005 _____, 26005 _____, 27005 _____, 28005 _____, 29005 _____, 30005 _____, 31005 _____, 32005 _____, 33005 _____, 34005 _____, 35005 _____, 36005 _____, 37005 _____, 38005 _____, 39005 _____, 40005 _____
25006-40006	Pager System Reports (p. 27) Off	25006 _____, 26006 _____, 27006 _____, 28006 _____, 29006 _____, 30006 _____, 31006 _____, 32006 _____, 33006 _____, 34006 _____, 35006 _____, 36006 _____, 37006 _____, 38006 _____, 39006 _____, 40006 _____
25007-40007	Partition/Area 1 Pager Reports (p. 27) Off	25007 _____, 26007 _____, 27007 _____, 28007 _____, 29007 _____, 30007 _____, 31007 _____, 32007 _____, 33007 _____, 34007 _____, 35007 _____, 36007 _____, 37007 _____, 38007 _____, 39007 _____, 40007 _____
25008-40008	Partition/Area 2 Pager Reports (p. 27) Off	25008 _____, 26008 _____, 27008 _____, 28008 _____, 29008 _____, 30008 _____, 31008 _____, 32008 _____, 33008 _____, 34008 _____, 35008 _____, 36008 _____, 37008 _____, 38008 _____, 39008 _____, 40008 _____

Table A14: Item Numbers Index and Record (Continued)

Item Number	Setting Reference and Default	Setting
25009-40009	Partition/Area 3 Pager Reports (p. 27) Off	25009 _____, 26009 _____, 27009 _____, 28009 _____, 29009 _____, 30009 _____, 31009 _____, 32009 _____, 33009 _____, 34009 _____, 35009 _____, 36009 _____, 37009 _____, 38009 _____, 39009 _____, 40009 _____
25010-40010	Partition/Area 4 Pager Reports (p. 27) Off	25010 _____, 26010 _____, 27010 _____, 28010 _____, 29010 _____, 30010 _____, 31010 _____, 32010 _____, 33010 _____, 34010 _____, 35010 _____, 36010 _____, 37010 _____, 38010 _____, 39010 _____, 40010 _____
25011-40011	Partition/Area 5 Pager Reports (p. 27) Off	25011 _____, 26011 _____, 27011 _____, 28011 _____, 29011 _____, 30011 _____, 31011 _____, 32011 _____, 33011 _____, 34011 _____, 35011 _____, 36011 _____, 37011 _____, 38011 _____, 39011 _____, 40011 _____
25012-40012	Partition/Area 6 Pager Reports (p. 27) Off	25012 _____, 26012 _____, 27012 _____, 28012 _____, 29012 _____, 30012 _____, 31212 _____, 32012 _____, 33012 _____, 34012 _____, 35012 _____, 36012 _____, 37012 _____, 38012 _____, 39012 _____, 40012 _____
25013-40013	Partition/Area 7 Pager Reports (p. 27) Off	25013 _____, 26013 _____, 27013 _____, 28013 _____, 29013 _____, 30013 _____, 31013 _____, 32013 _____, 33013 _____, 34013 _____, 350113 _____, 36013 _____, 37013 _____, 38013 _____, 39013 _____, 40013 _____
25014-40014	Partition/Area 8 Pager Reports (p. 27) Off	25014 _____, 26014 _____, 27014 _____, 28014 _____, 29014 _____, 30014 _____, 31014 _____, 32014 _____, 33014 _____, 34014 _____, 35014 _____, 36014 _____, 37014 _____, 38014 _____, 39014 _____, 40014 _____
25015-40015	Pager PIN (p. 27) None	25015 _____, 26015 _____, 27015 _____, 28015 _____, 29015 _____, 30015 _____, 31015 _____, 32015 _____, 33015 _____, 34015 _____, 35015 _____, 36015 _____, 37015 _____, 38015 _____, 39015 _____, 40015 _____
25016-40016	Pager Message Length (p. 27) 120 Characters	25016 _____, 26016 _____, 27016 _____, 28016 _____, 29016 _____, 30016 _____, 31016 _____, 32016 _____, 33016 _____, 34016 _____, 35016 _____, 36016 _____, 37016 _____, 38016 _____, 39016 _____, 40016 _____
47001	Add Zones (p. 31)	
47002	Delete Zones (p. 32)	
47003	List Zones (p. 33)	
47004	Zone Attributes (Edit Zones) (p. 33)	
47005	Test Buddies (p. 33)	
47006	List Buddies (p. 33)	
48001	Add (Learn) Bus Devices (p. 34)	
48002	Delete/Change Bus Device ID (p. 35)	
48003	List Bus Devices (p. 35)	

**Table A14: Item Numbers Index and Record (Continued)**

Item Number	Setting Reference and Default	Setting
48004	Bus Device Partition/Area (p. 35)	
48005	Change Transmit Bus ID (p. 35)	
48006	List Bus Device Text (p. 35)	
48007	Replace/Delete Bus Device ID (p. 36)	
48009	Program LED Module (p. 36)	
48010	Delete/Replace LED Module (p. 36)	
49001	Zone Text (p. 32)	
49002	Bus Device Text (p. 35)	
49003	Menu Output Text (p. 37)	
49004	Partition/Area Text (p. 17)	
49005	Keypad Idle Text (p. 36)	
50001	Reset Panel (p. 42)	
50002	Clear Memory (p. 15)	
50003	Software/Hardware Version (p. 42)	
50004	Clear History Buffer (p. 42)	
50005	Output Configuration (p. 37)	
50008-50009	Set Holiday Lists (p. 43)	
50010	Set Event Configuration and Alarm Masks (p. 43)	
50012	Print Zone & Device Information (p. 43)	
50013	Access Code Length (p. 24) 4	
50014-50015	Delete Primary/Secondary SnapCard (p. 44)	
50016	Print History Buffer (p. 44)	



## Appendix B: Reference Tables

This appendix contains tables for selecting zone type numbers, system features, X-10 Module house, unit codes and responses, SuperBus device unique ID numbers, and text

descriptor numbers. Table notes (if any) appear at the bottom of the last page of the table.

### Note

Fire zone types are always active.

**Table B1: Zone Type Characteristics**

No.	Name	Application	Active Level	Alarm/Siren	Delay	Supervisory	Restoral	CS Alarm Report	CS Cancel Report	Bypassable	Chime	Resets Activity Timer
00	Fixed Panic	24-hour audible fixed emergency buttons.	1, 2, 3, 4, 5	Police/Police	Instant	√		√	√	√		
01	Portable Panic	24-hour audible portable emergency buttons.	1, 2, 3, 4, 5	Police/Police	Instant			√	√	√		
02	Fixed Panic	24-hour silent fixed emergency buttons.	1, 2, 3, 4, 5	Police/Silent	Instant	√		√	√	√		
03	Portable Panic	24-hour silent portable emergency buttons.	1, 2, 3, 4, 5	Police/Silent	Instant			√	√	√		
04	Fixed Auxiliary	24-hour auxiliary sensor, such as Pendant Panic or holdup button.	1, 2, 3, 4, 5	Aux./ Aux.	Instant	√		√	√	√		
05	Fixed Auxiliary	24-hour auxiliary emergency buttons. Siren shut-off confirms CS alarm report.	1, 2, 3, 4, 5	Aux./ Aux.	Instant	√		√	√	√		
06	Portable Auxiliary	24-hour portable auxiliary alert buttons.	1, 2, 3, 4, 5	Aux./ Aux.	Instant			√	√	√		
07	Portable Auxiliary	24-hour portable auxiliary button. Siren shut-off confirms CS alarm report.	1, 2, 3, 4, 5	Aux./ Aux.	Instant			√	√	√		
08	Special Intrusion	Special belongings, such as gun cabinets and wall safes.	1, 2, 3, 4, 5	Police/Police	Instant	√	√	√	√	√		
09	Special Intrusion	Special belongings, such as gun cabinets and wall safes.	1, 2, 3, 4, 5	Police/Police	Standard	√	√	√	√	√		
10	Entry/Exit Delay	Entry and exit doors that require a standard delay time.	2, 3, 4, 5	Police/Police	Standard	√	√	√	√	√	√	√
11	Entry/Exit Delay	Garage doors and entrances that require an extended delay time. *	2, 3, 4, 5	Police/Police	Extended	√	√	√	√	√	√	
12	Entry/Exit Delay	Driveway gates and entrances that require a twice extended delay time. *	2, 3, 4, 5	Police/Police	Twice Extended	√	√	√	√	√	√	
13	Instant Perimeter	Exterior doors and windows.	2, 3, 4, 5	Police/Police	Instant	√	√	√	√	√	√	√
14	Instant Interior	Interior doors.	2, 3, 4, 5	Police/Police	Follower	√	√	√	√	√		√
15	Instant Interior	Interior PIR motion sensors. *	2, 3, 4, 5	Police/Police	Follower	√		√	√	√		√
16	Instant Interior	Interior doors.	3, 4, 5	Police/Police	Follower	√	√	√	√	√		√
17	Instant Interior	PIR motion sensors. *	3, 4, 5	Police/Police	Follower	√		√	√	√		√
18	Cross Zone Instant Interior	PIR motion sensors subject to false alarms. * †	3, 4, 5	Police/Police	Follower	√		√	√	√		√
19	Delayed Interior	Interior doors that initiate a delay before going into alarm.*	3, 4, 5	Police/Police	Standard	√	√	√	√	√		√

**Table B1: Zone Type Characteristics (Continued)**

No.	Name	Application	Active Level	Alarm/Siren	Delay	Supervisory	Restoral	CS Alarm Report	CS Cancel Report	Bypassable	Chime	Resets Activity Timer
20	Delayed Interior	PIR motion sensors that initiate a delay before going into alarm. *	3, 4, 5	Police/Police	Standard	√		√	√	√		√
21	Local Instant Interior	24-hour local alarm zone protecting anything that opens and closes.	1, 2, 3, 4, 5	Police/Police	Instant	√	√			√		√
22	Local Delayed Interior	Same as type 21, plus activation initiates a delay before going into alarm.	1, 2, 3, 4, 5	Police/Police	Standard	√	√			√		√
23	Local Instant Auxiliary	24-hour local alarm zone protecting anything that opens and closes. ‡	1, 2, 3, 4, 5	Aux./Aux.	Instant	√	√			√		
24	Local Instant Auxiliary	24-hour local alarm zone protecting anything that opens and closes. Sirens shut off at restoral. *	1, 2, 3, 4, 5	Aux./Aux.	Instant	√	√			√		
25	Local Special Chime	Notify the user when a door is opened. Sounds emit from a local annunciator. *	1, 2, 3, 4, 5	Special Chime	Instant	√	√			√	√	
26	Fire	24-hour audible fire emergency buttons, rate-of-rise heat, and smoke sensors.	1, 2, 3, 4, 5	Fire/Fire	Instant	√	√	√	√			
27	Custom Output	Output, lamp control, or other customer feature. ‡	1, 2, 3, 4, 5	Silent	Instant	√	√			√		
28	Custom Output	Output, PIR motion sensor, sound sensor, or pressure mat. ‡	1, 2, 3, 4, 5	Silent	Instant	√				√		
29	Auxiliary	Auxiliary.	1, 2, 3, 4, 5	Aux.	Instant	√	√	√	√	√		
30 (A)	Report Police	24-hour audible police alarm in levels 2 and 3.	2, 3, 4, 5	Police/Police	Instant	√	√	√	√	√		
30 (B)	Local Auxiliary	24-hour audible auxiliary alarm in level 1. Siren shut off at restoral.	1	Aux./Aux.	Instant	√	√			√		
32	Custom Output	Output, PIR motion sensor, sound sensor, or pressure mat. ‡	1, 2, 3, 4, 5	Silent	Instant					√		
36 (A)	Report Police	24-hour audible police alarm in levels 2 and 3.	2, 3, 4, 5	Police/Police	Instant	√	√	√	√	√		
36 (B)	Local Auxiliary	24-hour audible auxiliary alarm in level 1.	1	Aux./Aux.	Instant	√	√			√		
50	Local Instant Interior	24-hour local alarm zone protecting anything that opens and closes.	2, 3, 4, 5	Police/Police	Instant	√	√			√		√
51	Local Delayed Interior	24-hour local alarm zone protecting anything that opens and closes.	2, 3, 4, 5	Police/Police	Standard	√	√			√		√
52	Local Indicator	24-hour local auxiliary alarm zone protecting anything that opens and closes. No voice. Sirens shut off at restoral. *	1, 2, 3, 4, 5	Aux./Aux.	Instant	√	√			√		

**Table B1: Zone Type Characteristics (Continued)**

No.	Name	Application	Active Level	Alarm/Siren	Delay	Supervisory	Restoral	CS Alarm Report	CS Cancel Report	Bypassable	Chime	Resets Activity Timer
53	Local Indicator	24-hour local indicator zone protecting anything that opens and closes. Chime only.	1, 2, 3, 4, 5	None	Instant	√	√			√	√	
54	Fixed Medical	24-hour audible fixed medical emergency buttons.	1, 2, 3, 4, 5	Medical/Medical	Instant	√		√	√	√		
55	Fixed Medical	24-hour audible fixed medical emergency buttons. Sirens shut off when reported.	1, 2, 3, 4, 5	Medical/Medical	Instant	√		√	√	√		
56	Portable Medical	24-hour audible portable medical emergency buttons.	1, 2, 3, 4, 5	Medical/Medical	Instant			√	√	√		
57	Portable Medical	24-hour audible portable medical emergency buttons. Sirens shut off when reported.	1, 2, 3, 4, 5	Medical/Medical	Instant			√	√	√		
58	Suspicion	If not canceled within 1-5 min., alarm may optionally be generated. A second trip within 1-5 min. will cause an alarm.	1, 2, 3, 4, 5	Suspicion/Silent	Instant	√		√	√	√		
59	Fire Keyswitch	Keyswitch used for enabling fire type touchpad.	1, 2, 3, 4, 5	Silent	Instant	√	√					
60 (A)	Police	24-hour audible police emergency buttons.	3, 5	Police/Police	Instant	√	√	√	√	√		
60 (B)	Fire	24-hour audible fire emergency buttons	1, 2, 4,	Fire/Fire	Instant	√	√	√	√	√		
61	Local Indicator/Delay Perimeter	Local beeps only in Level -1.	2, 3, 4, 5	Police/Police	Standard	√	√	√	√	√		√
62	Fire Panic	Fire Panic	1, 2, 3, 4, 5	Fire/Fire	Instant	√	√	√	√			
63	Equipment Tamper	24-hour audible security system panel tamper alarm.	1, 2, 3, 4, 5	Equipment Tamper/Police	Instant	√	√	√	√			
64	Equipment Tamper	24-hour silent security system panel tamper alarm.	1, 2, 3, 4, 5	Equipment Tamper/None	Instant	√	√	√	√			
65	Siren Tamper	24-hour audible siren tamper alarm.	1, 2, 3, 4, 5	Siren Tamper/Police	Instant	√	√	√	√			
66	Siren Tamper	24-hour silent siren tamper alarm.	1, 2, 3, 4, 5	Siren Tamper/None	Instant	√	√	√	√			
67		Unused.										
68	Carbon Monoxide	Carbon Monoxide gas detectors. Note: For residential use only.	1, 2, 3, 4, 5	Carbon Monoxide/Medical	Instant	√	√	√	√			
69	Touchpad disable keyswitch	Keyswitch for disabling touchpad.	1, 2, 3, 4, 5	None/None	Instant	√				√		
70	Warning	Trip plays programmable evacuation message.	1, 2, 3, 4, 5	None/None	Instant	√				√	√	
71	On/Off Key-switch	Trip causes arm. Restoral causes a disarm.	1, 2, 3, 4, 5	None/None	Instant	√	√					√

**Table B1: Zone Type Characteristics (Continued)**

No.	Name	Application	Active Level	Alarm/Siren	Delay	Supervisory	Restoral	CS Alarm Report	CS Cancel Report	Bypassable	Chime	Resets Activity Timer
72	Momentary Keyswitch	First trip arms, second trip disarms.	1, 2, 3, 4, 5	None/None	Instant	√						√
73	Fixed Holdup	24-hour silent fixed holdup emergency button alarm.	1, 2, 3, 4, 5	Holdup/None	Instant	√		√				
74	Portable Holdup	24-hour silent portable holdup emergency button alarm.	1, 2, 3, 4, 5	Holdup/None	Instant			√				
75	Night Interior	Disarmed in “night” level.	3, 5	Police/Police	Follower	√	√	√	√	√		√
76	Night Interior	Disarmed in “night” level.	3, 5	Police/Police	Follower	√		√	√	√		√
77	Cross Zone Night Delayed Interior	Disarmed in “night” level. †	3, 5	Police/Police	Follower	√		√	√	√		√
78	Night Delayed Interior	Disarmed in “night” level.	3, 5	Police/Police	Standard	√	√	√	√	√		√
79	Night Delayed Interior	Disarmed in “night” level.	3, 5	Police/Police	Standard	√		√	√	√		√
80	Smoke	24-hour audible smoke/fire alarm.	1, 2, 3, 4, 5, 6	Smoke/Fire	Instant	√	√	√	√			
81	Heat	24-hour audible heat/fire alarm.	1, 2, 3, 4, 5	Heat/Fire	Instant	√	√	√	√			
82	Water Flow	24-hour audible sprinkler/fire alarm.	1, 2, 3, 4, 5	Sprinkler/Fire	Instant	√	√	√	√			
83		Unused.										
84	Enhanced Buddy	Special enhanced “buddy system” function.	1, 2, 3, 4, 5	Buddy/None	Instant	√						
85	Repeater	Wireless signal repeaters	1, 2, 3, 4, 5	None/None	Instant	√						
86	Fixed Wireless Touchpad	Fixed (wall-mount) wireless touchpads	1, 2, 3, 4, 5	None/None	Instant	√						
87	Portable Wireless Touchpad	Portable (hand-held) wireless touchpads Note: For residential use only.	1, 2, 3, 4, 5	None/None	Instant							
88		Unused.										
89		Unused.										
90	Pump Active	Fire pump is active.	1, 2, 3, 4, 5	Fire/Fire	Instant	√	√	√	√			
91	Pump Failure	Fire pump has failed. §	1, 2, 3, 4, 5	Aux./Aux.	Instant	√	√					
92	Gate Valve Closed	Fire gate valve has been closed. §	1, 2, 3, 4, 5	Aux./Aux.	Instant	√	√					
93	CO2 Pressure	CO2 pressure is low. §	1, 2, 3, 4, 5	Aux./Aux.	Instant	√	√					
94	Liquid Pressure	Liquid pressure is low. §	1, 2, 3, 4, 5	Aux./Aux.	Instant	√	√					
95	Liquid Level	Liquid level is low. §	1, 2, 3, 4, 5	Aux./Aux.	Instant	√	√					

**Table B1: Zone Type Characteristics (Continued)**

No.	Name	Application	Active Level	Alarm/Siren	Delay	Supervisory	Restoral	CS Alarm Report	CS Cancel Report	Bypassable	Chime	Resets Activity Timer
96	Fire Supervisory	A fire supervisory trouble has been detected. §	1, 2, 3, 4, 5	Aux./Aux.	Instant	√	√					

**Note:** Check marks (√) represent characteristics present in a type.

\* This type is not certified as a primary protection circuit for UL-listed systems and is for supplementary use only.

† Sounds instant police siren if two or more sensors are tripped within 4 minutes; otherwise sensors are followers to delayed sensors. If central station Alarm Verification feature is on, type 18 functions like type 17.

‡ This type has not been investigated by UL.

§ Zone trip causes trouble, restoral causes trouble restoral.

#### Activity Levels as Follows:

Level #	Name	Description	Attributes
Level 1	OFF	The partition/area is disarmed. Only 24-hour sensors cause an alarm in the OFF level. Cancelling alarms or entry delay automatically disarms to OFF.	- Open - Entry, but no exit delay - Cannot be disabled
Level 2	PERIMETER/ HOME	The user is on-site and only requires perimeter protection. In addition to 24-hour sensors, perimeter sensors such as those protecting exterior doors and windows cause an alarm in the HOME/PERIMETER level.	- Closed - Entry and exit delay - Can be disabled
Level 3	FULL/AWAY	The user is away and requires complete protection. 24-hour sensors, perimeter sensors, and interior sensors cause an alarm in the AWAY/FULL level.	Same as Level 2.
Level 4	NIGHT	The user is on-site and perimeter and 24-hour sensors are active. Since users are not moving around, Interior sensors except those in night groups are also active.	Same as Level 2.
Level 5	SILENT	Same as Level 3, but police intrusion alarms are silent.	Same as Level 2.

**Table B2: Three-Digit Text Descriptors**

No.	Text Descriptor	No.	Text Descriptor	No.	Text Descriptor
001	0	043	11_	082	ADVENT_
002	1	044	12_	083	AGAIN_
003	2	765	24_	084	AGENT_
004	3	045	Dash	085	AIR_
005	4	046	Cursor	086	ALARM_
006	5	047	Space And 125 ms Pause	087	ALERT_
007	6	048	Space	088	ALL_
008	7	049	Blink Next Token	089	ALLEY_
009	8	050	Break Line (Return)	090	AN_
010	9	051	Period (Dot)	768	ANALOG_
011	10	052	Apostrophe	091	AND_
012	11	053	AM_	092	ANNEX_
013	12	054	PM_	093	ANNUNCIATOR_
014	13	055	125 ms Pause	094	ANTENNA_
015	14	056	250 ms Pause	095	APARTMENT_
016	15	057	500 ms Pause	096	APPLIANCE_
017	16	058	125 ms Beep	097	APRIL_
018	17	059	250 ms Beep	098	ARE_
019	18	060	500 ms Beep	099	AREA_
020	19	061	125 ms Low Beep	100	ARM_
021	20	062	250 ms Low Beep	101	ARMED_
022	30	063	500 ms Low Beep	102	ARMING_
023	40	064	Long Beep	103	ART_
024	50	065	Chime Ding	104	AS_
025	60	066	Chime Dong	105	ASSEMBLY_
026	70	067	A (display only)	106	ATTIC_
027	80	068	A	107	ATTRIBUTE_
028	90	069	A_ (short)	108	AUDIO_
029	100	070	ABORT_	109	AUGUST_
030	THOUSAND_	071	ABORTED_	110	AUTHORITY_
031	ONE_	072	ABOVE_	111	AUTO_
032	0_	766	AC_ (A.C.)	112	AUTO ARMING_
033	1_	073	ACCEPT_	113	AUTOMATIC_
034	2_	074	ACCESS_	114	AUTOMATION_
035	3_	075	ACKNOWLEDGE_	115	AUXILIARY_
036	4_	076	ACKNOWLEDGMENT_	116	AWAY_
037	5_	077	ACTIVE_	117	B (display only)
038	6_	078	ACTIVITY_	118	B
039	7_	079	ADD_	119	BABY'S_
040	8_	080	ADDED_	120	BACK_
041	9_	081	ADDRESS_	121	BACKUP_
042	10_	767	ADDRESSABLE_	122	BAD_

No.	Text Descriptor
123	BADGE_
124	BALCONY_
125	BAR_
126	BARN_
127	BASEMENT_
128	BATH_
129	BATTERY_
130	BAY_
131	BEDROOM_
769	BELL_
132	BLACK_
133	BLOWER_
134	BLUE_
135	BOAT_
136	BOILER_
137	BOTTOM_
770	BOX_
138	BREAK_
139	BREAKER_
140	BREATHING_
141	BREEZEWAY_
142	BRIGHTEN_
143	BROWN_
144	BUDDY_
145	BUFFER_
146	BUILDING_
147	BUS_
148	BUSINESS_
149	BUSY_
150	BYPASS_
151	BYPASSED_
152	C (display only)
153	C
154	CABIN_
155	CABINET_
156	CAGE_
771	CALL_
157	CALLER ID_
158	CAMERA_
159	CANCEL_
160	CANCELED_
161	CAR_
162	CARBON MONOXIDE_

No.	Text Descriptor
163	CASH_
164	CCTV_
165	CEILING_
166	CELLAR_
167	CELLULAR_
168	CENTER_
169	CENTRAL_
170	CHANGE_
171	CHANGED_
172	CHECK IN_
173	CHECKSUM_
174	CHIME_
772	CIRCUIT_
175	CLASS_
176	CLEAR_
177	CLEARED_
178	CLOSE_
179	CLOSED_
180	CLOSET_
181	CLOSING_
182	CO_
183	CO2_
184	COAT_
185	CODE_
186	CODE'S_
187	CODES_
188	COLLECTION_
189	Colon
190	COMMON_
191	COMMUNICATION_
192	COMMUNICATOR_
193	COMPLETE_
194	COMPUTER_
195	CONFERENCE_
196	CONFIGURATION_
197	CONSERVATORY_
198	CONTACT_
199	CONTINUE_
200	CONTROL_
201	COOLER_
202	CORRIDOR_
203	COTTAGE_
204	COUNT_

No.	Text Descriptor
205	COUNTER_
206	CPU_
207	CRITICAL_
208	CUSTOM_
209	D (display only)
210	D
211	DAMPER_
212	DATA_
213	DAUGHTER'S_
214	DAY_
215	DAYLIGHT_
216	DAYS_
773	DEALER_
217	DECEMBER_
218	DECK_
219	DEGREES_
220	DELAY_
221	DELETE_
222	DELETED_
223	DEN_
224	DESCRIPTORS_
225	DESK_
226	DETECTOR_
227	DEVICE_
228	DEVICES_
229	DIAL_
230	DIFFERENT_
231	DIM_
232	DINING_
233	DIRECT_
234	DISABLE_
235	DISABLED_
236	DISARM_
237	DISARMED_
774	DISPLAY_
238	DO_
775	DOCK_
239	DOES_ (long)
240	DOES_ (short)
241	DOOR_
242	DOWN_
243	DOWNLOAD_
244	DOWNSTAIRS_

No.	Text Descriptor
245	DRILL_
246	DRIVEWAY_
247	DRUG_
248	DUAL_
249	DUCT_
250	DURESS_
251	E (display only)
252	E
253	EARLY_
254	EAST_
255	EIGHTH_
776	ELECTRICAL_
256	ELEVATOR_
257	ELEVENTH_
258	EMERGENCY_
259	EMPLOYEE_
260	ENABLE_
261	ENERGY SAVER_
262	ENERGY SAVERS_
263	ENTER_
264	ENTERED_
265	ENTRANCE_
266	ENTRY_
267	ENVIRONMENTAL_
268	EQUIPMENT_
269	ERROR_
270	EVACUATION_
271	EVENT_
272	EXECUTIVE_
273	EXERCISE_
274	EXIST_
275	EXISTS_
276	EXIT_
277	EXPLOSIVE_
278	EXTEND_
279	EXTENDED_
280	EXTENSION_
281	EXTERIOR_
282	EXTINGUISHER_
283	F (display only)
284	F
285	FACTORY_
286	FAILED_

No.	Text Descriptor
287	FAILURE_
288	FAMILY_
289	FAN_
290	FATHER'S_
291	FAULT_
292	FEATURE_
293	FEATURES_
294	FEBRUARY_
295	FENCE_
296	FIFTH_
297	FILE_
298	FIRE_
299	FIRST_
777	FLAME_
300	FLASH_
301	FLOOD_
302	FLOOR_
303	FLOW_
304	FOR_
305	FORCE_
306	FORMAT_
307	FOURTH_
308	FOYER_
309	FREEZE_
310	FREEZER_
311	FRIDAY_
312	FROM_
313	FRONT_
314	FULL_
315	FURNACE_
316	G (display only)
317	G
318	GALLERY_
319	GAME_
320	GARAGE_
321	GARDEN_
322	GAS_
323	GATE_
324	GENERATOR_
778	GENERAL_
325	GLASS_
326	GLOBAL_
327	GOLD_

No.	Text Descriptor
328	GOOD_
329	GOODBYE_
330	GRAY_
331	GREEN_
332	GROUND_
333	GROUP_
334	GUARD_
335	GUEST_
336	GUN_
337	H (display only)
338	H
339	HALL_
340	HALLWAY_
341	HARDWIRE_
342	HEAD_
343	HEAT_
344	HEATER_
345	HEATING_
346	HELLO_
347	HELP_
348	HIGH_
349	HISTORY_
350	HOLDUP_
351	HOLIDAY_
352	HOME_
779	HORN_
353	HOT TUB_
354	HOUSE_
355	I (display only)
356	I
357	ID_
358	IN_
780	INDICATING_
359	INDIRECT_
360	INDOOR_
361	INFORMATION_
362	INFRARED_
363	INHIBIT_
781	INITIATING_
364	IN PROGRESS_
365	INPUT_
366	IN SERVICE_
367	INSIDE_



No.	Text Descriptor
368	INSTANT_
369	INTEGRATION_
370	INTERCOM_
371	INTERIOR_
372	INTRUSION_
373	INVALID_
374	IS_
375	ITEM_
376	J (display only)
377	J
378	JACUZZI_
379	JAM_
380	JANITOR_
381	JANUARY_
382	JEWELRY_
383	JOFFRE_
384	JULY_
385	JUNE_
386	K (display only)
387	K
782	KEY_
388	KEYFOB_
389	KEYSTROKE_
390	KEYSWITCH_
391	KITCHEN_
392	L (display only)
393	L
394	LADIES'_
395	LAKE_
396	LATCHKEY_
397	LATE_
398	LAUNDRY_
783	LED_ (L.E.D.)
399	LEARN_
400	LEFT_
401	LENGTH_
402	LEVEL_
403	LIBRARY_
404	LIGHT_
405	LIGHTING_
406	LIGHTS_
407	LIMIT_
408	LIMITS_

No.	Text Descriptor
409	LINE_
410	LIQUID_
411	LIQUOR_
412	LIST_
413	LISTEN_
414	LIVING_
415	LOBBY_
416	LOCAL_
417	LOCKOUT_
418	LOG_
419	LONG_
420	LOOP_
421	LOT_
422	LOUNGE_
423	LOW_
424	LOWER_
425	LTIME_
426	M (display only)
427	M
428	MACHINE_
429	MAID'S_
430	MAILBOX_
431	MAIN_
784	MAINTENANCE_
432	MALL_
433	MANAGER'S_
785	MANUAL_
434	MANUFACTURING_
435	MARCH_
786	MASK_
436	MASTER_
437	MAT_
438	MAY_
439	MECHANICAL_
440	MEDIA_
441	MEDICAL_
442	MEDICINE_
443	MEMORY_
444	MEN'S_
445	MENU_
446	MESSAGE_
447	MICROPHONE_
448	MICROWAVE_

No.	Text Descriptor
449	MIDNIGHT_
450	MINUTES_
451	MODE_
452	MODIFIER_
453	MODIFY_
454	MODULE_
455	MONDAY_
456	MONEY_
457	MOTHER'S_
458	MOTION_
459	MOTOR_
460	N (display only)
461	N
787	NAC_ ("knack")
462	NEGATIVE_
463	NEW_
464	NIGHT_
465	NINTH_
466	NO_
788	NON_
467	NON-REPORTING_
468	NOON_
469	NORMAL_
470	NORTH_
471	NOT_
472	NOVA ALERT_
473	NOVEMBER_
474	NOW_
475	NUMBER_
476	NUMBERS_
477	NURSERY_
478	O (display only)
479	O
480	OBSCURITY_
481	O'CLOCK_
482	OCTOBER_
483	OF_
484	OFF_
485	OFFICE_
486	0 (spoken as OH)
487	OK_
488	ON_
489	OPEN_

No.	Text Descriptor
490	OPENING_
491	OPTION_
492	OR_
493	ORANGE_
494	OUT_
495	OUTDOOR_
496	OUTPUT_
497	OVER_
498	P (display only)
499	P
500	PAGER_
501	PAINTING_
502	PANEL_
503	PANIC_
504	PANTRY_
505	PARENTS'_
506	PARKING_
507	PARTITION_
508	PATH_
509	PATIO_
510	PERIMETER_
511	PERIOD_
512	PERMANENT_
513	PHONE_
514	PHOTO_
515	PLACE_
516	PLANT_
517	PLEASE_
518	POLICE_
519	POOL_
789	PORCH
520	POSITIVE_
521	POUND_
522	#_ (spoken as Pound)
523	# (spoken as Pound)
524	POWER_
525	PREARM_
526	PRESS_
527	PRESS_ (on new line)
528	PRESSURE_
529	PRIMARY_
530	PRINTER_
531	PROGRAM_

No.	Text Descriptor
532	PROGRAMMING_
533	PROTEST_
534	PULL STATION_
535	PUMP_
536	PURPLE_
537	Q (display only)
538	Q
539	QUAD_
540	QUIET_
541	QUIT_
542	R (display only)
543	R
544	RADIO_
545	RAMP_
546	RANGE_
547	READY_
548	REAR_
790	RECALL
549	RECEIVER_
550	RECEIVING_
551	RECEPTION_
552	RECONNECT_
553	RED_
554	REDIRECT_
555	RELAY_
556	RELEASE_
557	REMOTE_
558	REMOVE_
559	REMOVED_
560	REPEATER_
561	REPORT_
791	REQUEST
562	RESET_
563	RESTORAL_
564	RESTORED_
565	RETURN_
566	REVIEW_
567	RF_
568	RIGHT_
569	RING_
570	ROOF_
571	ROOM_
572	S (display only)

No.	Text Descriptor
573	S
574	SAFE_
575	SATURDAY_
576	SAUNA_
577	SCHEDULE_
578	SCHEDULES_
579	SCHOOL_
580	SCREEN_
581	SCRIPT_
582	SCRIPTS_
583	2ND_
584	SECOND_
792	SECONDARY
585	SECONDS_
586	SECTION_
587	SECTOR_
588	SECURE_
589	SECURITY_
590	SELECTION_
793	SENSITIVITY
591	SENSOR_
592	SENSORS_
593	SEPTEMBER_
594	SERVANT_
595	SERVICE_
596	SET_
597	SETPOINT_
598	SETUP_
599	SEVENTH_
600	SHACK_
601	SHARED_
602	SHED_
603	SHEEP_
604	SHIPPING_
605	SHOCK_
606	SHOP_
607	SHORT_
794	SHUNT
795	SHUTDOWN
796	SIGNALING
608	SHUT OFF_
609	SIDE_
610	SIGNAL_

No.	Text Descriptor
611	SILENCE_
612	SILENT_
613	SILVER_
614	SIREN_
615	SITE_
616	SIXTH_
617	SKYLIGHT_
618	SLIDING_
619	SMOKE_
797	SNAPCARD
620	SON'S_
621	SOUND_
622	SOUTH_
623	SPEAKER_
624	SPECIAL_
798	SPECIFIC
625	SPRINKLER_
626	STAIR_
627	STAIRS_
628	STANDARD_
629	*_ (spoken as Star)
630	Flashing * -- do not use
631	* (spoken as Star)
632	START_
633	STARTING_
634	STATION_
635	STATUS_
636	STAY_
637	STIME_
638	STOP_
639	STORAGE_
640	STORE_
641	STORY_
642	STRIKE_
643	STRIP_
644	STROBE_
645	STUDY_
646	SUMP_
647	SUPERBUS_
648	SUPERVISORY_
649	SUSPICION_
650	SUNDAY_
651	SWIMMING_

No.	Text Descriptor
652	SWINGER_
653	SWITCH_
654	SYSTEM_
655	T (display only)
656	T
657	TAMPER_
658	TAMPERED_
659	TANK_
660	TAPE_
661	TELCO_
662	TELLER_
663	TEMPERATURE_
664	TEMPORARY_
665	TENTH_
666	TEST_
667	TESTED_
668	TEXT_
669	THE_ (short)
670	THEATER_
671	THE_ (spoken as short Thee)
672	THEN_
673	THERMOSTAT_
674	THIRD_
675	Dash (spoken as Through)
676	Dash_ (spoken as Through)
677	THURSDAY_
678	TIME_
679	TIMED_
680	TIMER_
681	TIMEOUT_
682	TO_
683	TONE_
684	TOOL_
685	TOOLBOX_
686	TOP_
687	TOUCHPAD_
688	TRAILER_
689	TRANSCEIVER_
690	TRANSMIT_
691	TRAP_
692	TRIES_
693	TRIP_
694	TROUBLE_

No.	Text Descriptor
695	TRUCK_
696	TUESDAY_
697	TURN_
698	TWELFTH_
699	TWICE_
700	TYPE_
701	U (display only)
702	U
703	A_ (spoken as Uh)
704	UNBYPASS_
705	UNDER_
706	UNIT_
707	UP_
799	UPLOAD
708	UPSTAIRS_
709	USE_
710	USED_
711	USER_
712	UserTokens -- do not use
713	USES_
714	UTILITY_
715	V (display only)
716	V
717	VALID_
718	VALUE_
719	VALVE_
720	VAULT_
800	VERIFICATION
721	VERSION_
722	VESTIBULE_
723	VIBRATION_
724	VIDEO_
725	VIEW_
726	VIOLATION_
727	VOICE_
728	EVAC MESSAGE 1
729	EVAC MESSAGE 2
730	EVAC MESSAGE 3
731	EVAC MESSAGE 4
732	EVAC MESSAGE 5
733	VOLTS_
734	VOLUME_
735	W (display only)

No.	Text Descriptor
736	W
737	WAIT_
738	WALL_
739	WAREHOUSE_
740	WARNING_
741	WASH_
742	WASHROOM_
743	WATER_
801	WEATHER
744	WEDNESDAY_
745	WEEK_

No.	Text Descriptor
746	WEEKLY_
802	WELL
747	WEST_
748	WHITE_
749	WINDOW_
750	WINE_
751	WING_
752	WORKSHOP_
753	X (display only)
754	X
755	Y (display only)

No.	Text Descriptor
756	Y
757	YARD_
758	YELLOW_
759	YES_
760	YOUR_
761	Z (display only)
762	Z
763	ZONE_
764	ZONES_

**Table B3: Two-Digit Display Descriptors**

No.	Token Text	No.	Token Text
00	0	29	M
01	1	30	N
02	2	31	O
03	3	32	P
04	4	33	Q
05	5	34	R
05	6	35	S
07	7	36	T
08	8	37	U
09	9	38	V
10	(undefined)	39	W
11	(undefined)	40	X
12	# (pound)	41	Y
13	: (colon)	42	Z
14	/ (slash)	43	_ (space)
15	? (question mrk)	44	' (apostrophe)
16	. (period)	45	-- (dash)
17	A	46	__ (underline)
18	B	47	* (star)
19	C	48	(time)
20	D	49	(date)
21	E	50	(day and date)
22	F	51	_(pseudo space)
23	G	52	(return)
24	H	53	* (Flashing star) Trouble Indicator
25	I		
26	J		
27	K		
28	L		

**Table B4: Panel House Code Defaults/Settings for 4 Partition Panels**

Partition/ Area	Panel House Code Defaults (HC1, HC2)	X-10 House Dial	House Code	X-10 House Dial
1	HC1 = 1 HC2 = 5	A E	___ ___	___ ___
2	HC1 = 2 HC2 = 6	B F	___ ___	___ ___
3	HC1 = 3 HC2 = 7	C G	___ ___	___ ___
4	HC1 = 4 HC2 = 8	D H	___ ___	___ ___

**Table B5: Panel House Code Defaults/Settings for 8 Partition Panels**

Partition/ Area	Panel House Code Defaults (HC1, HC2)	X-10 House Dial	House Code	X-10 House Dial
1	HC1 = 1 HC2 = 9	A I	___ ___	___ ___
2	HC1 = 2 HC2 = 10	B J	___ ___	___ ___
3	HC1 = 3 HC2 = 11	C K	___ ___	___ ___
4	HC1 = 4 HC2 = 12	D L	___ ___	___ ___
5	HC1 = 5 HC2 = 13	E M	___ ___	___ ___
6	HC1 = 6 HC2 = 14	F N	___ ___	___ ___
7	HC1 = 7 HC2 = 15	G O	___ ___	___ ___
8	HC1 = 8 HC2 = 16	H P	___ ___	___ ___

**Table B6: X-10 Module Operation**

Condition	Lamp Module Unit No. 1	Lamp Module Unit Nos. 2–16	Appliance/Universal Module Unit Nos. 2–16
On entry delay	On for 5 minutes	Unchanged	Unchanged
On Fire Alarm*	On	On	Unchanged
On Police Alarm*	On	On	Unchanged
On Auxiliary Alarm*	On	On	Unchanged
Lights On	On	On	Unchanged
Lights Off	Off	Off	Off
<i>* Fire alarms have priority over both police and auxiliary alarms. Police alarms have priority over auxiliary alarms.</i>			

**Table B7: X-10 and Non-X-10 Light/Device Numbers by Partition**

Partition 1	X-10 Unit Dial Setting	Light/Device Number	Menu Output Number
<b>House Code 1</b>			
	1	1	1
	2	2	2
	3	3	3
	4	4	4
	5	5	5
	6	6	6
	7	7	7
	8	8	8
	9	9	9
	10	10	10
	11	11	11
	12	12	12
	13	13	13
	14	14	14
	15	15	15
	16	16	16
<b>House Code 2</b>			
	1	17	17
	2	18	18
	3	19	19
	4	20	20
	5	21	21
	6	22	22
	7	23	23
	8	24	24
	9	25	25
	10	26	26
	11	27	27
	12	28	28
	13	29	29
	14	30	30
	15	31	31
	16	32	32
<b>Non-X-10</b>			
		33	33
		34	34
		35	35
		36	36
		37	37
		39	39
		40	40

Partition 2	X-10 Unit Dial Setting	Light/Device Number	Menu Output Number
<b>House Code 1</b>			
	1	1	41
	2	2	42
	3	3	43
	4	4	44
	5	5	45
	6	6	46
	7	7	47
	8	8	48
	9	9	49
	10	10	50
	11	11	51
	12	12	52
	13	13	53
	14	14	54
	15	15	55
	16	16	56
<b>House Code 2</b>			
	1	17	57
	2	18	58
	3	19	59
	4	20	60
	5	21	61
	6	22	62
	7	23	63
	8	24	64
	9	25	65
	10	26	66
	11	27	67
	12	28	68
	13	29	69
	14	30	70
	15	31	71
	16	32	72
<b>Non-X-10</b>			
		33	73
		34	74
		35	75
		36	76
		37	77
		39	79
		40	80

Partition 3	X-10 Unit Dial Setting	Light/Device Number	Menu Output Number
<b>House Code 1</b>			
	1	1	81
	2	2	82
	3	3	83
	4	4	84
	5	5	85
	6	6	86
	7	7	87
	8	8	88
	9	9	89
	10	10	90
	11	11	91
	12	12	92
	13	13	93
	14	14	94
	15	15	95
	16	16	96
<b>House Code 2</b>			
	1	17	97
	2	18	98
	3	19	99
	4	20	100
	5	21	101
	6	22	102
	7	23	103
	8	24	104
	9	25	105
	10	26	106
	11	27	107
	12	28	108
	13	29	109
	14	30	110
	15	31	111
	16	32	112
<b>Non-X-10</b>			
		33	113
		34	114
		35	115
		36	116
		37	117
		39	119
		40	120

Partition 4	X-10 Unit Dial Setting	Light/Device Number	Menu Output Number
<b>House Code 1</b>			
	1	1	121
	2	2	122
	3	3	123
	4	4	124
	5	5	125
	6	6	126
	7	7	127
	8	8	128
	9	9	129
	10	10	130
	11	11	131
	12	12	132
	13	13	133
	14	14	134
	15	15	135
	16	16	136
<b>House Code 2</b>			
	1	17	137
	2	18	138
	3	19	139
	4	20	140
	5	21	141
	6	22	142
	7	23	143
	8	24	144
	9	25	145
	10	26	146
	11	27	147
	12	28	148
	13	29	149
	14	30	150
	15	31	151
	16	32	152
<b>Non-X-10</b>			
		33	153
		34	154
		35	155
		36	156
		37	157
		39	159
		40	160

Partition 5	X-10 Unit Dial Setting	Light/Device Number	Menu Output Number
<b>House Code 1</b>			
	1	1	161
	2	2	162
	3	3	163
	4	4	164
	5	5	165
	6	6	166
	7	7	167
	8	8	168
	9	9	169
	10	10	170
	11	11	171
	12	12	172
	13	13	173
	14	14	174
	15	15	175
	16	16	176
<b>House Code 2</b>			
	1	17	177
	2	18	178
	3	19	179
	4	20	180
	5	21	181
	6	22	182
	7	23	183
	8	24	184
	9	25	185
	10	26	186
	11	27	187
	12	28	188
	13	29	189
	14	30	190
	15	31	191
	16	32	192
<b>Non-X-10</b>			
		33	193
		34	194
		35	195
		36	196
		37	197
		39	199
		40	200

Partition 6	X-10 Unit Dial Setting	Light/Device Number	Menu Output Number
<b>House Code 1</b>			
	1	1	201
	2	2	202
	3	3	203
	4	4	204
	5	5	205
	6	6	206
	7	7	207
	8	8	208
	9	9	209
	10	10	210
	11	11	211
	12	12	212
	13	13	213
	14	14	214
	15	15	215
	16	16	216
<b>House Code 2</b>			
	1	17	217
	2	18	218
	3	19	219
	4	20	220
	5	21	221
	6	22	222
	7	23	223
	8	24	224
	9	25	225
	10	26	226
	11	27	227
	12	28	228
	13	29	229
	14	30	230
	15	31	231
	16	32	232
<b>Non-X-10</b>			
		33	233
		34	234
		35	235
		36	236
		37	237
		39	239
		40	240



Partition 7	X-10 Unit Dial Setting	Light/Device Number	Menu Output Number
<b>House Code 1</b>			
	1	1	241
	2	2	242
	3	3	243
	4	4	244
	5	5	245
	6	6	246
	7	7	247
	8	8	248
	9	9	249
	10	10	250
	11	11	251
	12	12	252
	13	13	253
	14	14	254
	15	15	255
	16	16	256
<b>House Code 2</b>			
	1	17	257
	2	18	258
	3	19	259
	4	20	260
	5	21	261
	6	22	262
	7	23	263
	8	24	264
	9	25	265
	10	26	266
	11	27	267
	12	28	268
	13	29	269
	14	30	270
	15	31	271
	16	32	272
<b>Non-X-10</b>			
		33	273
		34	274
		35	275
		36	276
		37	277
		39	279
		40	280

Partition 8	X-10 Unit Dial Setting	Light/Device Number	Menu Output Number
<b>House Code 1</b>			
	1	1	281
	2	2	282
	3	3	283
	4	4	284
	5	5	285
	6	6	286
	7	7	287
	8	8	288
	9	9	289
	10	10	290
	11	11	291
	12	12	292
	13	13	293
	14	14	294
	15	15	295
	16	16	296
<b>House Code 2</b>			
	1	17	297
	2	18	298
	3	19	299
	4	20	300
	5	21	301
	6	22	302
	7	23	303
	8	24	304
	9	25	305
	10	26	306
	11	27	307
	12	28	308
	13	29	309
	14	30	310
	15	31	311
	16	32	312
<b>Non-X-10</b>			
		33	313
		34	314
		35	315
		36	316
		37	317
		39	319
		40	320

### Contact ID Codes and Event Types

Use Table B8 for determining event types and CID codes.

**Note**  
Items in grey are not supported.

**Table B8: Contact ID Codes**

Description	Specific Type	Contact ID Code	Associated Zone Type
<b>Alarms</b> (General Types 1–Alarm, 2–Alarm Cancel, 3–Alarm Restoral)			
<b>Note:</b> All alarm cancels are reported as CID code 406			
*Advent has a defined level that reports “silent burglary” (CID 146). This will be used in place of the defined event code at the appropriate level.			
Unspecified	0	140	
Fire	1	110	26, 90
Fire Panic	2	115	60(B), 62, Touchpad Panics
Police	3	130	8, 9, 30*, 60(A), 61*, 64*, 75-79*
Police Panic	4	120	0, 1, Touchpad Panics
Medical	5	100	4-7, Touchpad Panics
Medical Panic	6	101	54-57, Touchpad Panics
Auxiliary	7	140	
Auxiliary Panic	8	100	4-7, Touchpad Panics
Tamper	9	144	63*, 65*, 66*, 85, Any Zone
No Activity	10	102	
Suspicion	11	122	2, 3, 58, 73, 74
Buddy	12	140	
Low Temperature Limit	13	159	
High Temperature Limit	14	158	
Keystroke Violation	15	145	
Duress	16	121	
Exit Fault	17	374	
Explosive Gas	18	151	34, 67
Carbon Monoxide	19	162	68
Environmental	20	150	29
Latchkey	21	642	
Equipment Tamper	22	137	
Holdup	23	122	2, 3, 58, 73, 74
Sprinkler	24	113	82
Heat	25	114	81
Siren Tamper	26	137	

**Table B8: Contact ID Codes (Continued)**

Description	Specific Type	Contact ID Code	Associated Zone Type
Smoke	27	111	80
Repeater	28	144	63*, 65*, 66*, 85, Any Zone
Fire Pump Activated	29	110	26, 90
Fire Pump Failure	30	140	
Fire Gate Valve	31	140	
Low CO2 Pressure	32	140	
Low Liquid Pressure	33	140	
Low Liquid Level	34	140	
Entry Exit Intrusion (Police)	35	134	10-12*
Perimeter Intrusion (Police)	36	131	13*
Interior Intrusion (Police)	37	132	14-20*
Fire Supervisory	38	140	
<b>Fire Trouble</b> (General Types 4–Zone Trouble Fire, 5–Zone Trouble Restoral Fire)			
Unspecified	0	373	
Hardwire Trouble	1	373	
Ground Fault	2	310	
Device Trouble	3	373	
RF Supervisory	4	381	
RF Low Battery	5	384	
Tamper	6	383	
Suspected Sensor Failure	7	373	
Partial Obscurity	8	386	
RF Jam	9	373	
Zone AC Failure	10	373	
Zone Low Battery	11	373	
NAC Trouble	12	373	
Analog Zone Trouble	13	373	
Fire Supervisory Trouble	14	200	96
Pump Failure	15	206	91
Gate Valve Closed	16	203	92
CO2 Pressure	17	202	93
Liquid Pressure	18	201	94
Liquid Level	19	204	95
<b>Non-Fire Trouble</b> (General Types 6–Zone Trouble Non Fire, 7–Zone Trouble Restoral Non Fire)			
Unspecified	0	380	
Hardwire Trouble	1	380	
Ground Fault	2	310	

Table B8: Contact ID Codes (Continued)

Description	Specific Type	Contact ID Code	Associated Zone Type
Device Trouble	3	380	
RF Supervisory	4	381	
RF Low Battery	5	384	
Tamper	6	383	
Suspected Sensor Failure	7	391	
Partial Obscurity	8	386	
RF Jam	9	380	
Zone AC Failure	10	380	
Zone Low Battery	11	380	
NAC Trouble	12	380	
Analog Zone Trouble	13	380	
Fire Supervisory Trouble	14	200	96
Pump Failure	15	206	91
Gate Valve Closed	16	203	92
CO2 Pressure	17	202	93
Liquid Pressure	18	201	94
Liquid Level	19	204	95
<b>Bypass and Unbypass</b> (General Types 8–Bypass, 9–Unbypass)			
Direct	0	570	
Indirect	1	570	
Swinger	2	575	
Inhibit	3	570	
<b>Opening</b> (General Type 10–Opening)			
Normal	0	401	
Early	1	451	
Late	2	452	
Fail	3	453	
Exception	4	450	
Extension	5	450	
Keystroke/Keyfob Disarm	6	409	
Scheduled Disarm	7	403	
Remote	8	407	
<b>Closing</b> (General Type 11–Closing)			
Normal	0	401	
Early	1	451	
Late	2	452	
Fail	3	454	
Exception	4	450	

Table B8: Contact ID Codes (Continued)

Description	Specific Type	Contact ID Code	Associated Zone Type
Extension	5	464	
Keystroke/Keyfob Disarm	6	409	
Scheduled Disarm	7	403	
Remote	8	407	
<b>Partition/Area Configuration Change</b> (General Type 12–Partition/Area Configuration Change)			
Access Code Added	0	306	
Access Code Deleted	1	306	
Access Code Changed	2	306	
Access Code Expired	3	306	
Code Authority Changed	4	306	
Authority Level Changed	5	306	
Schedule Changed	6	306	
Arm/OC Schedule Changed	7	632	
Zone Added	8	306	
Zone Deleted	9	306	
<b>Partition/Area Event</b> (General Type 13–Partition/Area Event)			
Schedule On	0	300	
Schedule Off	1	300	
Latchkey On	2	300	
Latchkey Off	3	300	
Smoke Loop Reset	4	300	
Access Code Entered	5	462	
Arming Level Change	6	300	
Alarm Reported	7	300	
Agent Release	8	300	
Agent Release Restoral	9	300	
Remote Access	10	410	
Keystroke Violation	11	300	
Manual Force Arm	12	401	
Auto Force Arm	13	457	
Force Arm Failed	14	455	
Protest Start	15	300	
Protest End	16	300	
<b>Partition/Area Test</b> (General Type 14– Partition/Area Test)			
Manual Phone Test	0	601	
Auto Phone Test	1	602	
Off-Normal Auto Phone Test	2	608	

Table B8: Contact ID Codes (Continued)

Description	Specific Type	Contact ID Code	Associated Zone Type
Phone Test Passed	3	300	
Phone Test Failed	4	300	
User Zone Test Started	5	607	
User Zone Test Ended	6	607	
User Zone Test Complete	7	607	
User Zone Test Incomplete	8	607	
User Zone Test Trip	9	611	
Installer Zone Test Started	10	607	
Installer Zone Test Ended	11	607	
Installer Zone Test Complete	12	607	
Installer Zone Test Incomplete	13	607	
Installer Zone Test Trip	14	611	
Fire Drill	15	604	
<b>System Trouble</b> (General Types 15–System Trouble, 16–System Trouble Restoral)			
Receiver Failure	0	355	
Antenna Tamper	1	355	
Main Low Battery	2	302	
SnapCard Low Battery	3	302	
Module Low Battery	4	338	
Main AC Power Failure	5	301	
Snap Card AC Power Failure	6	301	
Module AC Power Failure	7	342	
Auxiliary Power Failure	8	330	
Shutdown	9	308	
Bus Low Power Mode	10	330	
Phone Line #1 Failure (will be reported to phone 2)	11	351	
Phone Line #2 Failure (will be reported to phone 1)	12	352	
Remote Phone Tamper	13	413	
Watchdog Reset	14	305	
RAM Failure	15	303	
Flash Error	16	304	
Printer Trouble	17	336	
History Buffer Full	18	623	
History Buffer Overflow	19	624	
Report Buffer Overflow	20	624	
Bus Device Failure	21	333	

Table B8: Contact ID Codes (Continued)

Description	Specific Type	Contact ID Code	Associated Zone Type
Failure to Communicate	22	354	
Long Range Radio Trouble	23	353	
Module Tamper	24	341	
Unenrolled Module	25	333	
Audio Amplifier Trouble	26	320	33
Analog Module Trouble	27	333	
Cell Module Trouble	28	333	
Buddy #1 Failure	29	334	84, 85
Buddy #2 Failure	30	334	84, 85
Buddy #3 Failure	31	334	84, 85
Buddy #4 Failure	32	334	84, 85
SnapCard Trouble	33	333	
Analog Loop Short	34	332	
Analog Loop Break	35	331	
Analog Head at Address 0	36	333	
Unenrolled Analog Head	37	333	
Duplicate Analog Head	38	333	
Analog Loop Initializing	39	333	
Microphone Switch Trouble	40	333	
Microphone Trouble	41	333	
Microphone Audio Trouble	42	333	
JTech Module Trouble	43	333	
Voice Siren Tamper	44	320	33
Microburst Transmit Fault	45	353	
Microburst Disabled	46	353	
Microburst Module Failure	47	353	
Microburst not in service	48	353	
Microburst Module Supervisory	49	333	
<b>System Configuration Change</b> (General Type 17–System Configuration Change)			
Program Mode Entry	0	627	
Program Mode Exit No Change	1	628	
Program Mode Exit With Change	2	306	
Download Started	3	412	
Download Ended No Change	4	416	
Download Ended With Change	5	412	
Download Error	6	413	

**Table B8: Contact ID Codes (Continued)**

Description	Specific Type	Contact ID Code	Associated Zone Type
Download Denied	7	413	
Date/Time Changed	8	625	
Expansion Module Added	9	531	
Expansion Module Deleted	10	532	
Speech Tokens Changed	11	306	
Program Code Changed	12	306	
First Service -- Cold Reset	13	305	
Back in Service -- Warm Reset	14	308	
Installer Code Changed	15	306	
<b>System Event</b> (General Type 18–System Event)			
Callback Requested	0	411	
Output Activity	1	300	
Buddy Reception	2	300	
Buddy Transmit Request	3	300	
History Buffer Cleared	4	621	
Output On	5	300	
Output Off	6	300	
<b>System Test</b> (General Type 19–System Test)			
Manual Phone Test	0	601	
Auto Phone Test	1	602	
Off-Normal Auto Phone Test	2	608	
Phone Test Passed	3	300	
Phone Test Failed	4	300	

**Additional CID Reporting**

Table B9 shows additional CID reports.

**Table B9: Additional CID Reporting**

Type	Number Range	Example
System Reports	00	System low battery would report as 000.
Normal Zones	01–499	Zone number 4 would report as 004.
Bus Devices	500–594	Device number 1 would report as 501.
Touchpad Panic Zones	595–599	Touchpad fire panic would report as 599 Touchpad police panic would report as 598. Touchpad auxiliary panic would report as 597. Touchpad medical panic would report as 596. <b>Note:</b> Only if setting yy005 is on.
User	600–849	User number 52 would report as 652.
Local Phone Reports	900	Local phone panic would report as 900.
Remote Phone Reports	901	Remote phone, phone test would report as 901.
Installer Code	999	Alarm cancelled with installer code would report as 999.

**Table B10: LED Types and Behavior**

LED Types			LED Type Behavior		
LED Type	Description	LED Data	When the Green LED is On	When the Yellow LED is On	When the RED LED is On
0	Disable all LED's (default)				
1	Zone status type 1	Zone number	Zone normal	Zone in trouble or bypassed	Zone in alarm
2	Zone status type 2	Zone number	Zone normal	Zone open, in trouble, or bypassed	Zone in alarm
3	Zone status type 3	Zone number	Zone normal	Zone in trouble or bypassed	Zone open (unrestored)
4	Programmable output status type 1	Output number	Output off	Output on	
5	Programmable output status type 2	Output number	Output off		Output on
6	Arming level	Partition/Area	Partition/Area disarmed		Partition/Area armed
7	Alarm/Trouble status	Partition/Area	Partition/Area normal	Partition/Area in trouble	Partition/Area in alarm
8	System trouble		No system trouble	System trouble	
9	Main AC trouble		Main AC on	Main AC off	
10	SnapCard AC trouble		SnapCard AC on	SnapCard AC off	
11	Module AC trouble		Module AC on	Module AC off	
12	Auxiliary power trouble		Auxiliary power OK	Auxiliary power trouble	
13	Main battery trouble		Main battery(s) OK	Main battery(s) low	
14	SnapCard battery trouble		SnapCard battery(s) OK	SnapCard battery(s) low	
15	Module battery trouble		Module battery OK	Module battery(s) low.	

**Note:** If no LEDs are on, either the group is not programmed or the partition/area is not enabled.

## Smoke and Heat Detector Installation

Smoke and heat detector installation must adhere to the following diagram:

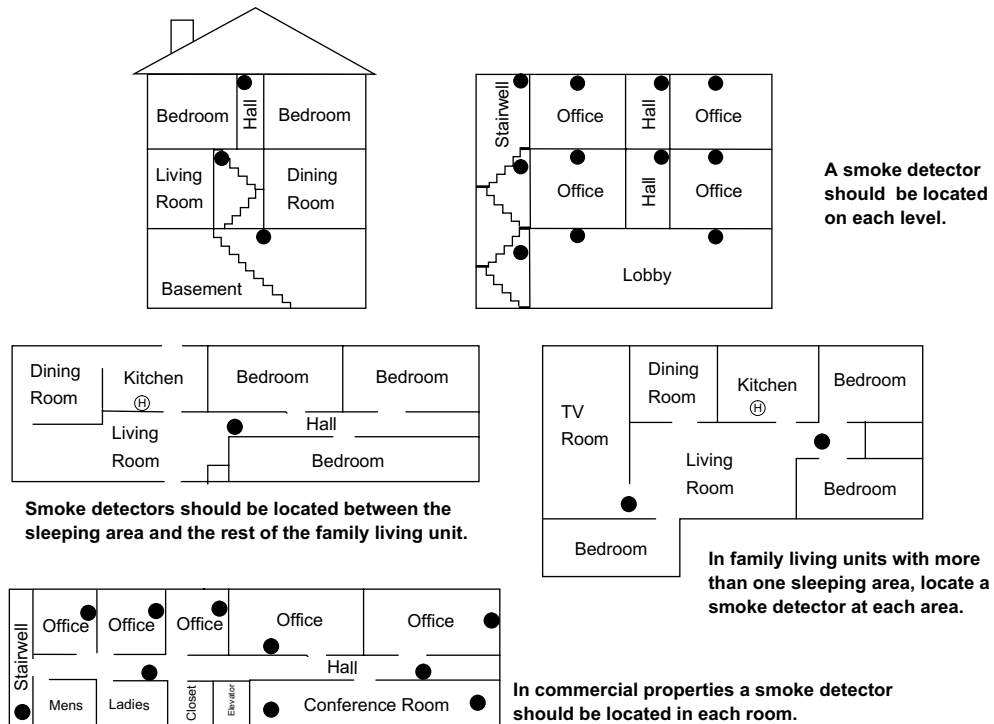

**NOTE:** Ceiling-mounted smoke detectors should be located in the center of the room or hall, or not less than 4 inches from the wall. When the detector is mounted on the wall, the top of the detector should be 4 to 12 inches from the ceiling.

**NOTE:** Do not install smoke detectors where normal ambient temperatures are above 100°F or below 40°F. Also, do not locate detectors in front of AC/ Heat registers or other locations where normal air circulation will keep smoke from entering the detector.

**NOTE:** Additional information on household fire warning is available at nominal cost from: The National Fire Protection Association, Batterymarch Park, Quincy, MA 02269. Request Standard No. NFPA74.

● Required smoke detector

Ⓜ Heat detector

Smoke detector is optional if door is not provided between basement and recreation rooms.

8557g160a.dsf





# ITI ADVENT COMMERCIAL BURGLARY AND HOME NAVIGATOR SYSTEM

60-562-01, 60-562-04, AND 60-562-02, 60-562-05

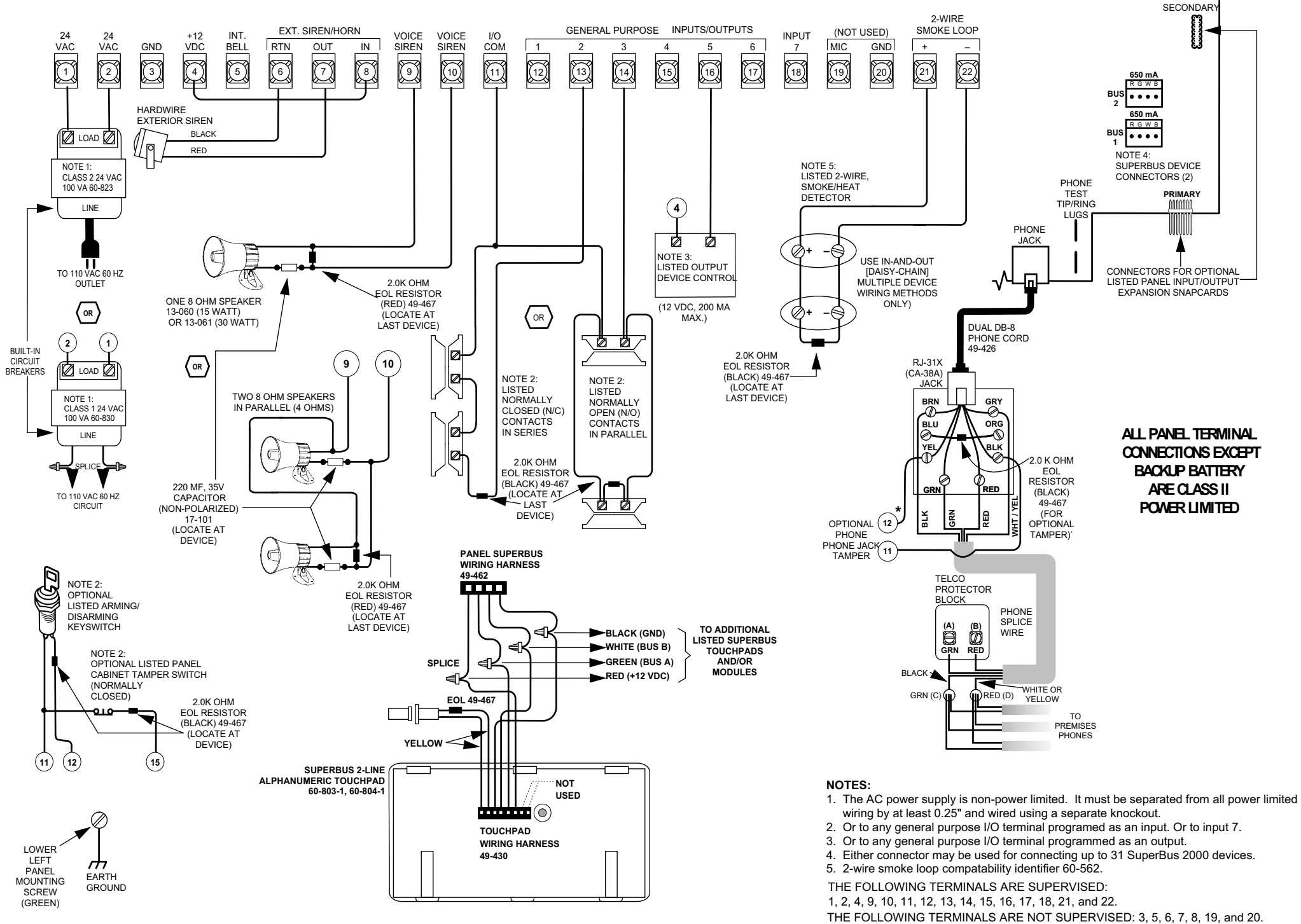



SECURITY & LIFE SAFETY GROUP

CARDIX | ESL | GRC | ITI | KALATEL | SENTROL

2266 SECOND STREET NORTH | NORTH SAINT PAUL MN | 55109 | 800-777-2624 | [www.interlogixinc.com](http://www.interlogixinc.com)

©2001 Interlogix,™ Inc. Interlogix is a trademark of Interlogix, Inc. ITI, Advent, and SuperBus are registered trademarks of Interlogix, Inc.